



THE ELECTRIC POTENTIAL

- 2.1** Line Integral of the Electric Field 42
- 2.2** Potential Difference and the Potential Function 44
- 2.3** Gradient of a Scalar Function 46
- 2.4** Derivation of the Field from the Potential 48
- 2.5** Potential of a Charge Distribution 49
 - Potential of Two Point Charges 49
 - Potential of a Long Charged Wire 50
- 2.6** Uniformly Charged Disk 51
- 2.7** Divergence of a Vector Function 56
- 2.8** Gauss's Theorem and the Differential Form of Gauss's Law 58
- 2.9** The Divergence in Cartesian Coordinates 59
- 2.10** The Laplacian 63
- 2.11** Laplace's Equation 64
- 2.12** Distinguishing the Physics from the Mathematics 66
- 2.13** The Curl of a Vector Function 68
- 2.14** Stokes' Theorem 70
- 2.15** The Curl in Cartesian Coordinates 71
- 2.16** The Physical Meaning of the Curl 74
- Problems 80

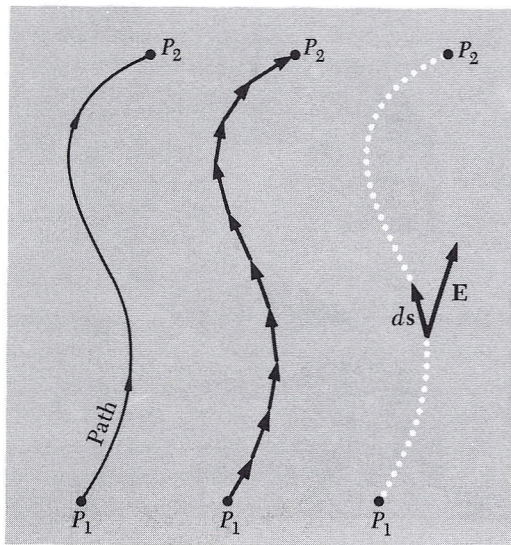

FIGURE 2.1

Showing the division of the path into path elements ds .

LINE INTEGRAL OF THE ELECTRIC FIELD

2.1 Suppose that \mathbf{E} is the field of some stationary distribution of electric charges. Let P_1 and P_2 denote two points anywhere in the field.

The line integral of E between the two points is $\int_{P_1}^{P_2} \mathbf{E} \cdot d\mathbf{s}$,

taken along some path that runs from P_1 to P_2 , as in Fig. 2.1. This means: Divide the chosen path into short segments, each segment being represented by a vector connecting its ends; take the scalar product of the path-segment vector with the field \mathbf{E} at that place; add these products up for the whole path. The integral as usual is to be regarded as the limit of this sum as the segments are made shorter and more numerous without limit.

Let's consider the field of a point charge q and some paths running from point P_1 to point P_2 in that field. Two different paths are shown in Fig. 2.2. It is easy to compute the line integral of \mathbf{E} along path A , which is made up of a radial segment running outward from P_1 and an arc of radius r_2 . Along the radial segment of path A , \mathbf{E} and $d\mathbf{s}$ are parallel, the magnitude of \mathbf{E} is q/r^2 , and $\mathbf{E} \cdot d\mathbf{s}$ is simply $(q/r^2) ds$. Thus the line integral on that segment is

$$\int_{r_1}^{r_2} \frac{q}{r^2} dr = q \left(\frac{1}{r_1} - \frac{1}{r_2} \right) \quad (1)$$

The second leg of path A , the circular segment, gives zero because \mathbf{E} is perpendicular to $d\mathbf{s}$ everywhere on that arc. The entire line integral is therefore

$$\int_{P_1}^{P_2} \mathbf{E} \cdot d\mathbf{s} = q \left(\frac{1}{r_1} - \frac{1}{r_2} \right) \quad (2)$$

Now look at path B . Because \mathbf{E} is radial with magnitude q/r^2 , $\mathbf{E} \cdot d\mathbf{s} = (q/r^2) dr$ even when $d\mathbf{s}$ is not radially oriented. The corresponding pieces of path A and path B indicated in the diagram make identical contributions to the integral. The part of path B that loops beyond r_2 makes a net contribution of zero; contributions from corresponding outgoing and incoming parts cancel. For the entire line integral, path B will give the same result as path A . As there is nothing special about path B , Eq. 1 must hold for *any* path running from P_1 to P_2 .

Here we have essentially repeated, in different language, the argument in Section 1.5, illustrated in Fig. 1.5, concerning the work done in moving one point charge near another. But now we are interested in the total electric field produced by any distribution of charges. One more step will bring us to an important conclusion. The line integral of the sum of fields equals the sum of the line integrals of the

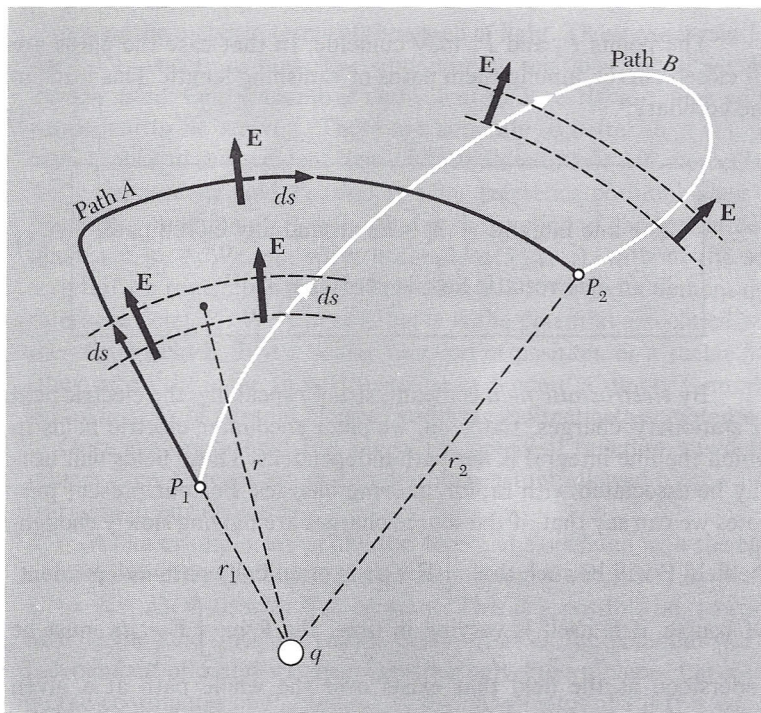
**FIGURE 2.2**

The electric field \mathbf{E} is that of a positive point charge q . The line integral of \mathbf{E} from P_1 to P_2 along path A has the value $q(1/r_1 - 1/r_2)$. It will have exactly the same value if calculated for path B, or for any other path from P_1 to P_2 .

fields calculated separately. Or, stated more carefully, if $\mathbf{E} = \mathbf{E}_1 + \mathbf{E}_2 + \dots$, then

$$\int_{P_1}^{P_2} \mathbf{E} \cdot d\mathbf{s} = \int_{P_1}^{P_2} \mathbf{E}_1 \cdot d\mathbf{s} + \int_{P_1}^{P_2} \mathbf{E}_2 \cdot d\mathbf{s} + \dots \quad (3)$$

where the same path is used for all the integrations. Now any electrostatic field can be regarded as the sum of a number (possibly enormous) of point-charge fields, as expressed in Eq. 1.14 or 1.15. Therefore if the line integral from P_1 to P_2 is independent of path for each of the point-charge fields $\mathbf{E}_1, \mathbf{E}_2, \dots$, the total field \mathbf{E} must have this property:

The line integral $\int_{P_1}^{P_2} \mathbf{E} \cdot d\mathbf{s}$ for any electrostatic field \mathbf{E} has the same value for all paths from P_1 to P_2

(4)

The points P_2 and P_1 may coincide. In that case the paths are all closed curves, among them paths of vanishing length. This leads to the corollary:

The line integral $\int \mathbf{E} \cdot d\mathbf{s}$ around any closed path
in an electrostatic field is zero

(5)

By *electrostatic field* is meant, strictly speaking, the electric field of stationary charges. Later on, we shall encounter electric fields in which the line integral is *not* path-independent. Those fields will usually be associated with rapidly moving charges. For our present purposes we can say that, if the source charges are moving slowly enough, the field \mathbf{E} will be such that $\int \mathbf{E} \cdot d\mathbf{s}$ is practically path-independent. Of course, if \mathbf{E} itself is varying in time, the \mathbf{E} in $\int \mathbf{E} \cdot d\mathbf{s}$ must be understood as the field that exists over the whole path at a given instant of time. With that understanding we can talk meaningfully about the line integral in a changing electrostatic field.

POTENTIAL DIFFERENCE AND THE POTENTIAL FUNCTION

2.2 Because the line integral in the electrostatic field is path-independent, we can use it to define a scalar quantity ϕ_{21} , without specifying any particular path:

$$\phi_{21} = - \int_{P_1}^{P_2} \mathbf{E} \cdot d\mathbf{s} \quad (6)$$

Thus ϕ_{21} is the work per unit charge done in moving a positive charge from P_1 to P_2 in the field \mathbf{E} . Thus ϕ_{21} is a single-valued scalar function of the two positions P_1 and P_2 . We call it the *electric potential difference* between the two points.

In our CGS system of units, potential difference is measured in erg/esu. This unit has a name of its own, the statvolt (“stat” comes from “electrostatic”). The volt is the unit of potential difference in SI units, the system in which the coulomb is the unit of charge and the joule the unit of energy. One joule (10^7 ergs) of work is required to move a charge of one coulomb through a potential difference of one volt. The exact relations between CGS and SI electrical units are given in Appendix E, taking into account the very recent official redef-

inition of the meter in terms of the speed of light. Those exact relations need not concern us now. Two approximate relations are all we shall usually need: One coulomb is equivalent to 3×10^9 esu. One volt is equivalent to $\frac{1}{300}$ statvolt. These are accurate to better than 0.1 percent, thanks to the accident that c is that close to 3×10^8 meters/sec.

Suppose we hold P_1 fixed at some reference position. Then ϕ_{21} becomes a function of P_2 only, that is, a function of the spatial coordinates x, y, z . We can write it simply $\phi(x, y, z)$, without the subscript, if we remember that its definition still involves agreement on a reference point P_1 . We can say that ϕ is the potential associated with the vector field \mathbf{E} . It is a scalar function of position, or a scalar field (they mean the same thing). Its value at a point is simply a number (in units of work per unit charge) and has no direction associated with it. Once the vector field \mathbf{E} is given, the potential function ϕ is determined, except for an arbitrary additive constant allowed by the arbitrariness in our choice of P_1 .

As an example, let us find the potential associated with the electric field described in Fig. 2.3, the components of which are: $E_x = Ky$, $E_y = Kx$, $E_z = 0$, with K a constant. This is a possible electrostatic field. Some field lines are shown. Since $E_z = 0$, the potential will be independent of z and we need consider only the xy plane. Let x_1, y_1 be the coordinates of P_1 , and x_2, y_2 the coordinates of P_2 . It is convenient to locate P_1 at the origin: $x_1 = 0, y_1 = 0$. To evaluate $-\int \mathbf{E} \cdot d\mathbf{s}$ from this reference point to a general point (x_2, y_2) it is easiest to use a path like the dotted path ABC in Fig. 2.3.

$$\begin{aligned} \phi(x_2, y_2) &= - \int_{(0,0)}^{(x_2,y_2)} \mathbf{E} \cdot d\mathbf{s} \\ &= - \int_{(0,0)}^{(x_2,0)} E_x dx - \int_{(x_2,0)}^{(x_2,y_2)} E_y dy \quad (7) \end{aligned}$$

The first of the two integrals on the right is zero because E_x is zero along the x axis. The second integration is carried out at constant x , with $E_y = Kx_2$:

$$- \int_{(x_2,0)}^{(x_2,y_2)} E_y dy = - \int_0^{y_2} Kx_2 dy = -Kx_2y_2 \quad (8)$$

There was nothing special about the point (x_2, y_2) so we can drop the subscripts:

$$\phi = -Kxy \quad (9)$$

for the potential at any point (x, y) in this field, with zero potential at the origin. Any constant could be added to this. That would only mean that the reference point to which zero potential is assigned had been located somewhere else.

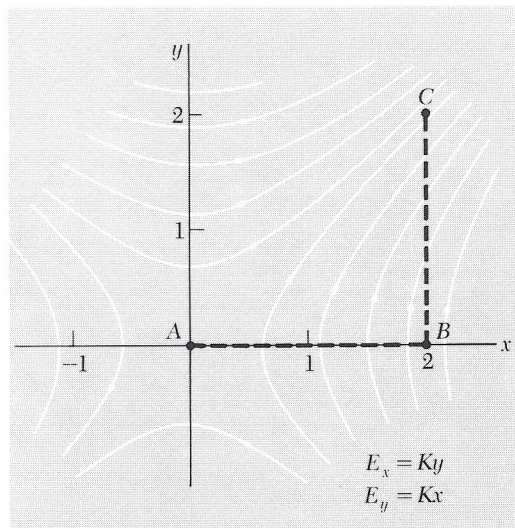

FIGURE 2.3

(a) A particular path, ABC , in the electric field $E_x = Ky$, $E_y = Kx$. Some field lines are shown.

We must be careful not to confuse the potential ϕ associated with a given field \mathbf{E} with the potential energy of a system of charges. The potential energy of a system of charges is the total work required to assemble it, starting with all the charges far apart. In Eq. 1.8, for example, we expressed U , the potential energy of the charge system in Fig. 1.6. The electric potential $\phi(x, y, z)$ associated with the field in Fig. 1.6 would be the work per unit charge required to move a unit positive test charge from some chosen reference point to the point (x, y, z) in the field of that structure of eight charges.

GRADIENT OF A SCALAR FUNCTION

2.3 Given the electric field, we can find the electric potential function. But we can also proceed in the other direction; from the potential we can derive the field. It appears from Eq. 6 that the field is in some sense the *derivative* of the potential function. To make this idea precise we introduce the *gradient* of a scalar function of position. Let $f(x, y, z)$ be some continuous, differentiable function of the coordinates. With its partial derivatives $\partial f/\partial x$, $\partial f/\partial y$, and $\partial f/\partial z$ we can construct at every point in space a vector, the vector whose x , y , z components are equal to the respective partial derivatives.† This vector we call the *gradient* of f , written “grad f ,” or ∇f .

$$\nabla f = \hat{\mathbf{x}} \frac{\partial f}{\partial x} + \hat{\mathbf{y}} \frac{\partial f}{\partial y} + \hat{\mathbf{z}} \frac{\partial f}{\partial z} \quad (10)$$

∇f is a vector that tells how the function f varies in the neighborhood of a point. Its x component is the partial derivative of f with respect to x , a measure of the rate of change of f as we move in the x direction. The direction of the vector ∇f at any point is the direction in which one must move from that point to find the most rapid increase in the function f . Suppose we were dealing with a function of two variables only, x and y , so that the function could be represented by a surface in three dimensions. Standing on that surface at some point, we see the surface rising in some direction, sloping downward in the opposite direction. There is a direction in which a short step will take us higher than a step of the same length in any other direction. The gradient of

†We remind the reader that a partial derivative with respect to x , of a function of x , y , z , written simply $\partial f/\partial x$, means the rate of change of the function with respect to x with the other variables y and z held constant. More precisely,

$$\frac{\partial f}{\partial x} = \lim_{\Delta x \rightarrow 0} \frac{f(x + \Delta x, y, z) - f(x, y, z)}{\Delta x}$$

As an example, if $f = x^2yz^3$,

$$\frac{\partial f}{\partial x} = 2xyz^3 \quad \frac{\partial f}{\partial y} = x^2z^3 \quad \frac{\partial f}{\partial z} = 3x^2yz^2$$

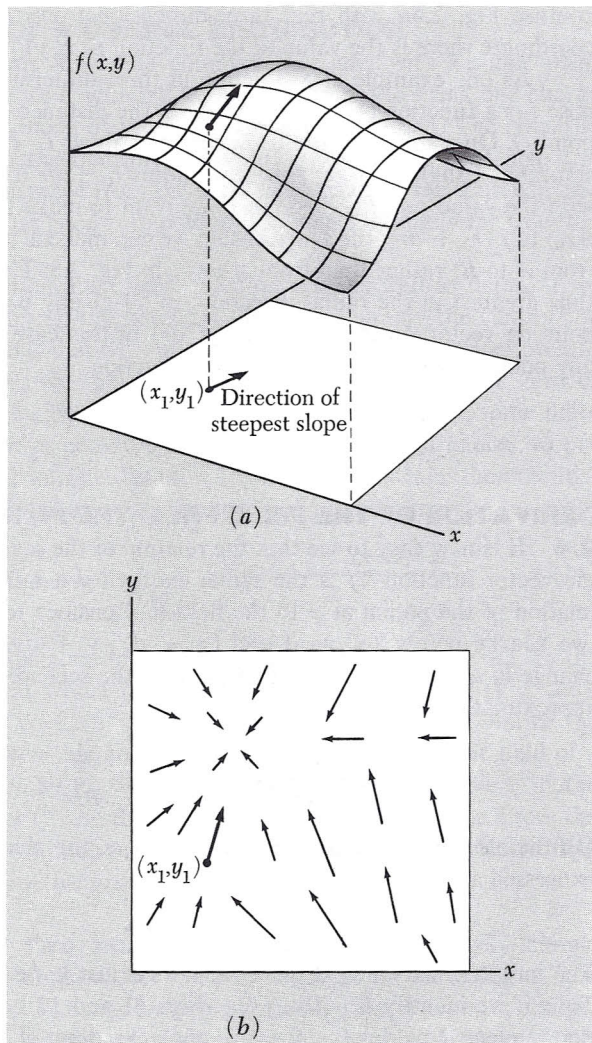
**FIGURE 2.4**

The scalar function $f(x, y)$ is represented by the surface in (a). The arrows in (b) represent the vector function, $\text{grad } f$.

the function is a vector in that direction of steepest ascent, and its magnitude is the slope measured in that direction.

Figure 2.4 may help you to visualize this. Suppose some particular function of two coordinates x and y is represented by the surface $f(x, y)$ sketched in Fig. 2.4a. At the location (x_1, y_1) the surface rises most steeply in a direction that makes an angle of about 80° with the positive x direction. The gradient of $f(x, y)$, ∇f , is a vector function of x and y . Its character is suggested in Fig. 2.4b by a number of vectors at various points in the two-dimensional space, including the point (x_1, y_1) . The vector function ∇f defined in Eq. 10 is simply an extension of this idea to three-dimensional space. [Be careful not to

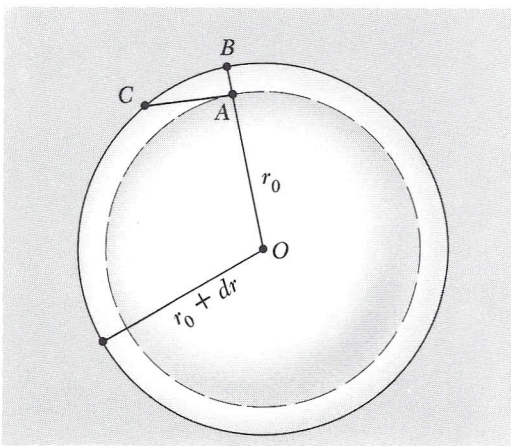
**FIGURE 2.5**

The shortest step for a given change in f is the radial step AB , if f is a function of r only.

confuse Fig. 2.4a with real three-dimensional xyz space; the third coordinate there is the value of the function $f(x, y)$.]

As one example of a function in three-dimensional space, suppose f is a function of r only, where r is the distance from some fixed point O . On a sphere of radius r_0 centered about O , $f = f(r_0)$ is constant. On a slightly larger sphere of radius $r_0 + dr$ it is also constant, with the value $f = f(r_0 + dr)$. If we want to make the change from $f(r_0)$ to $f(r_0 + dr)$, the shortest step we can make is to go radially (as from A to B) rather than from A to C , in Fig. 2.5. The “slope” of f is thus greatest in the radial direction, so ∇f at any point is a radially pointing vector. In fact $\nabla f = \hat{\mathbf{r}} (df/dr)$ in this case, $\hat{\mathbf{r}}$ denoting, for any point, a unit vector in the radial direction.

DERIVATION OF THE FIELD FROM THE POTENTIAL

2.4 It is now easy to see that the relation of the scalar function f to the vector function ∇f is the same, except for a minus sign, as the relation of the potential φ to the field \mathbf{E} . Consider the value of φ at two nearby points, (x, y, z) and $(x + dx, y + dy, z + dz)$. The change in φ , going from the first point to the second, is in first-order approximation

$$d\varphi = \frac{\partial \varphi}{\partial x} dx + \frac{\partial \varphi}{\partial y} dy + \frac{\partial \varphi}{\partial z} dz \quad (11)$$

On the other hand, from the definition of φ , the change can also be expressed as

$$d\varphi = -\mathbf{E} \cdot d\mathbf{s} \quad (12)$$

The infinitesimal vector displacement $d\mathbf{s}$ is just $\hat{\mathbf{x}} dx + \hat{\mathbf{y}} dy + \hat{\mathbf{z}} dz$. Thus if we identify \mathbf{E} with $-\nabla\varphi$, Eqs. 11 and 12 become identical. So the electric field is the negative of the gradient of the potential:

$$\mathbf{E} = -\nabla\varphi \quad (13)$$

The minus sign came in because the electric field points from a region of positive potential toward a region of negative potential, whereas the vector $\nabla\varphi$ is defined so that it points in the direction of increasing φ .

To show how this works, we go back to the example of the field in Fig. 2.3. From the potential given by Eq. 9, $\varphi = -Kxy$, we can recover the electric field we started with:

$$\begin{aligned} \mathbf{E} &= -\nabla(-Kxy) \\ &= -\left(\hat{\mathbf{x}} \frac{\partial}{\partial x} + \hat{\mathbf{y}} \frac{\partial}{\partial y}\right)(-Kxy) = K(\hat{\mathbf{x}}y + \hat{\mathbf{y}}x) \end{aligned} \quad (14)$$

POTENTIAL OF A CHARGE DISTRIBUTION

2.5 We already know the potential that goes with a single point charge, because we calculated the work required to bring one charge into the neighborhood of another in Eq. 3 of Chapter 1. The potential at any point, in the field of an isolated point charge q , is just q/r , where r is the distance from the point in question to the source q , and where we have assigned zero potential to points infinitely far from the source.

Superposition must work for potentials as well as fields. If we have several sources, the potential function is simply the sum of the potential functions that we would have for each of the sources present alone—*providing* we make a consistent assignment of the zero of potential in each case. If all the sources are contained in some finite region, it is always possible, and usually the simplest choice, to put zero potential at infinite distance. If we adopt this rule, the potential of any charge distribution can be specified by the integral:

$$\varphi(x, y, z) = \int_{\text{All sources}} \frac{\rho(x', y', z') dx' dy' dz'}{r} \quad (15)$$

where r is the distance from the volume element $dx' dy' dz'$ to the point (x, y, z) at which the potential is being evaluated (Fig. 2.6). That is, $r = [(x - x')^2 + (y - y')^2 + (z - z')^2]^{1/2}$. Notice the difference between this and the integral giving the electric field of a charge distribution (Eq. 15 of Chapter 1). Here we have r in the denominator, not r^2 , and the integral is a scalar not a vector. From the scalar potential function $\varphi(x, y, z)$ we can always find the electric field by taking the negative gradient of φ , according to Eq. 13.

Potential of two point charges. Consider a very simple example, the potential of the two point charges shown in Fig. 2.7. A positive charge of 12 esu is located 3 cm away from a negative charge, -6 esu. The potential at any point in space is the sum of the potentials due to each charge alone. The potentials for some selected points in space are given in the diagram. No vector addition is involved here, only the algebraic addition of scalar quantities. For instance, at the point on the far right which is 6 cm from the positive charge and 5 cm from the negative charge, the potential has the value $\frac{12}{6} + (-\frac{6}{5}) = 0.8$. The unit here comes out esu/cm, which is the same as erg/esu, or *statvolts*. The potential approaches zero at infinite distance. It would take 0.8 erg of work to bring a unit positive charge in from infinity to a point where $\varphi = 0.8$ statvolt. Note that two of the points shown on the diagram have $\varphi = 0$. The net work done in bringing in any charge to one of these points would be zero. You can see that there must be an infinite number of such points, forming a surface in space surrounding the negative charge. In fact the locus of points

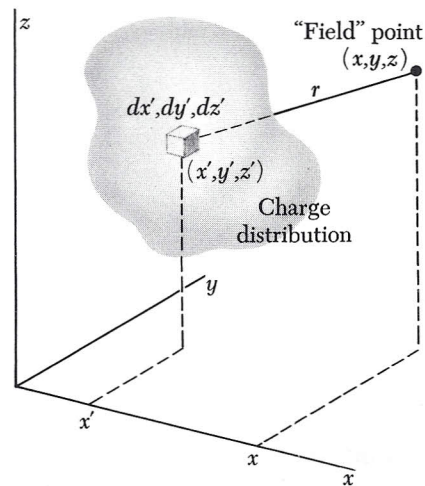

FIGURE 2.6

Each element of the charge distribution $\rho(x', y', z')$ contributes to the potential ϕ at the point (x, y, z) . The potential at this point is the sum of all such contributions (Eq. 15).

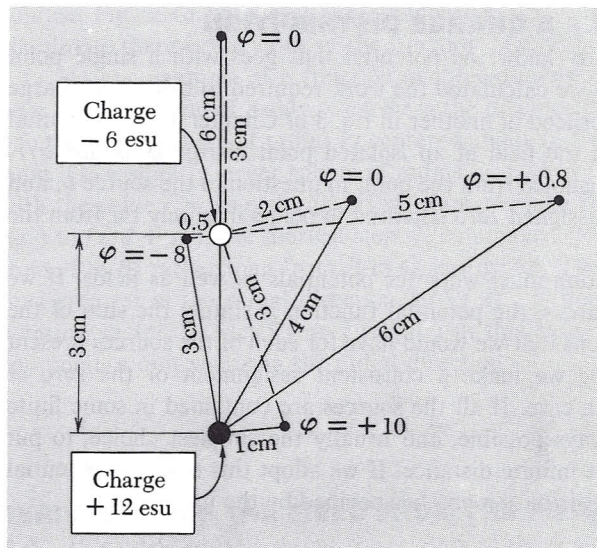

FIGURE 2.7

The electric potential ϕ at various points in a system of two point charges. ϕ goes to zero at infinite distance. ϕ is given in units of statvolts, or ergs per unit charge.

with any particular value of φ is a surface—an *equipotential surface*—which would show on our two-dimensional diagram as a curve.

Potential of a long charged wire. There is one restriction on the use of Eq. 15: It may not work unless all sources are confined to some finite region of space. A simple example of the difficulty that arises with charges distributed out to infinite distance is found in the long charged wire whose field \mathbf{E} we studied in Section 1.12. If we attempt to carry out the integration over the charge distribution indicated in Eq. 15, we find that the integral diverges—we get an infinite result. No such difficulty arose in finding the electric *field* of the infinitely long wire, because the contributions of elements of the line charge to the field decrease so rapidly with distance. Evidently we had better locate the zero of potential somewhere close to home, in a system which has charges distributed out to infinity. Then it is simply a matter of calculating the difference in potential φ_{21} , between the general point (x, y, z) and the selected reference point, using the fundamental relation, Eq. 6.

To see how this goes in the case of the infinitely long charged wire, let us arbitrarily locate the reference point P_1 at a distance r_1 from the wire. Then to carry a charge from P_1 to any other point P_2 at distance r_2 requires the work per unit charge

$$\begin{aligned}\varphi_{21} &= - \int_{P_1}^{P_2} \mathbf{E} \cdot d\mathbf{s} = - \int_{r_1}^{r_2} \left(\frac{2\lambda}{r} \right) dr \\ &= -2\lambda \ln r_2 + 2\lambda \ln r_1\end{aligned}\quad (16)$$

This shows that the electrical potential for the charged wire can be taken as

$$\varphi = -2\lambda \ln r + \text{const} \quad (17)$$

The constant, $2\lambda \ln r_1$ in this case, has no effect when we take $-\text{grad } \varphi$ to get back to the field \mathbf{E} . In this case

$$-\nabla\varphi = -\hat{\mathbf{r}} \frac{d\varphi}{dr} = \frac{2\lambda\hat{\mathbf{r}}}{r} \quad (18)$$

UNIFORMLY CHARGED DISK

2.6 Let us study, as a concrete example, the electric potential and field around a uniformly charged disk. This is a charge distribution like that discussed in Section 1.13, except that it has a limited extent. The flat disk of radius a in Fig. 2.8 carries a positive charge spread over its surface with the constant density σ , in esu/cm². (This is a single sheet of charge of infinitesimal thickness, not two layers of charge, one on each side. That is, the total charge in the system is $\pi a^2\sigma$.) We shall often meet surface charge distributions in the future, especially on metallic conductors. However, the object just described is *not* a conductor; if it were, as we shall soon see, the charge could not remain uniformly distributed but would redistribute itself, crowding more toward the rim of the disk. What we have is an insulating disk, like a sheet of plastic, upon which charge has been “sprayed” so that every square centimeter of the disk has received, and holds fixed, the same amount of charge.

As a start, let's find the potential at some point P_1 on the axis of symmetry, which we have made the y axis. All charge elements in a thin, ring-shaped segment of the disk lie at the same distance from P_1 . If s denotes the radius of such an annular segment and ds is its width, its area is $2\pi s ds$. The amount of charge it contains, dq , is therefore $dq = \sigma 2\pi s ds$. All parts of this ring are the same distance away from P_1 , namely, $r = \sqrt{y^2 + s^2}$, so the contribution of the ring to the potential at P_1 is dq/r , or $2\pi\sigma s ds/\sqrt{y^2 + s^2}$. To get the potential due to the whole disk, we have to integrate over all such rings:

$$\begin{aligned} \varphi(0, y, 0) &= \int \frac{dq}{r} = \int_0^a \frac{2\pi\sigma s ds}{\sqrt{y^2 + s^2}} \\ &= 2\pi\sigma \left[\sqrt{y^2 + s^2} \right]_{s=0}^{s=a} \end{aligned} \quad (19)$$

The integral happened to be an elementary one; on substituting $u = \sqrt{y^2 + s^2}$ it takes the form $\int u^{-1/2} du$. Putting in the limits, we obtain

$$\varphi(0, y, 0) = 2\pi\sigma (\sqrt{y^2 + a^2} - y) \quad \text{for } y > 0 \quad (20)$$

FIGURE 2.8

Finding the potential at a point P_1 on the axis of a uniformly charged disk.

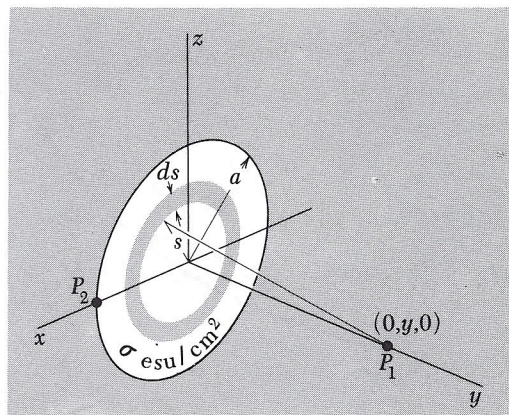

A minor point deserves a comment: The result we have written down in Eq. 20 holds for all points on the *positive* y axis. It is obvious from the physical symmetry of the system (there is no difference between one face of the disk and the other) that the potential must have the same value for negative and positive y , and this is reflected in Eq. 19, where only y^2 appears. But in writing Eq. 20 we made a choice of sign in taking the square root of y^2 , with the consequence that it holds *only* for positive y . The correct expression for $y < 0$ is obtained by the other choice of root and is

$$\varphi(0, y, 0) = 2\pi\sigma(\sqrt{y^2 + a^2} + y) \quad \text{for } y < 0 \quad (21)$$

In view of this, we should not be surprised to find a singularity in $\varphi(0, y, 0)$ at $y = 0$. Indeed, the function has an abrupt change of slope there, as we see in Fig. 2.9, where we have plotted as a function of y the potential on the axis. The potential at the center of the disk is $\varphi(0, 0, 0) = 2\pi\sigma a$. That much work would be required to bring a unit positive charge in from infinity, by any route, and leave it sitting at the center of the disk.

The behavior of $\varphi(0, y, 0)$ for very large y is interesting. For $y \gg a$ we can approximate Eq. 20 as follows:

$$\begin{aligned} \sqrt{y^2 + a^2} - y &= y \left[\left(1 + \frac{a^2}{y^2} \right)^{1/2} - 1 \right] \\ &= y \left[1 + \frac{1}{2} \left(\frac{a^2}{y^2} \right) \cdots - 1 \right] \approx \frac{a^2}{2y} \end{aligned} \quad (22)$$

FIGURE 2.9

A graph of the potential on the axis. The dashed curve is the potential of a point charge $q = \pi a^2 \sigma$.

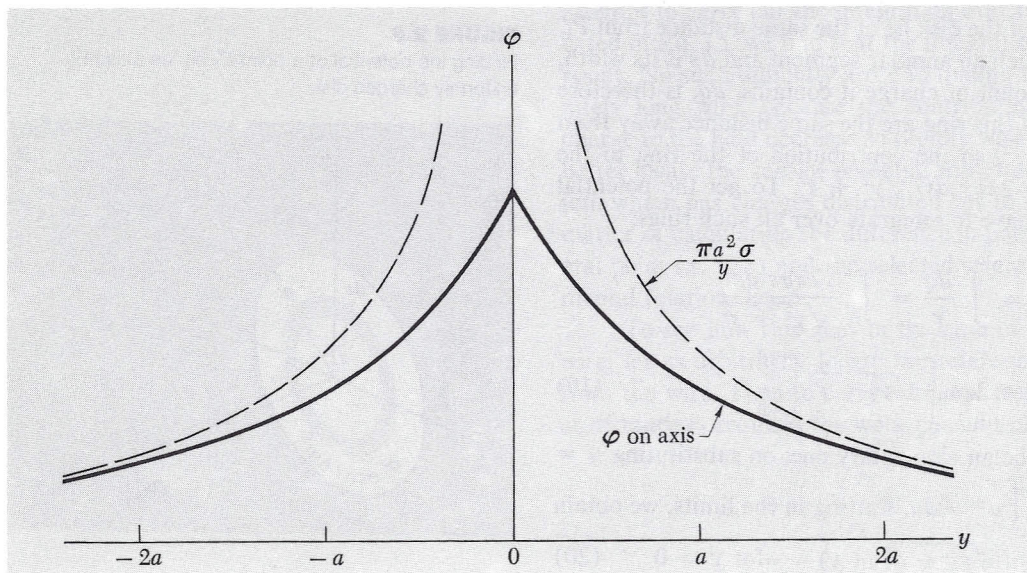

Hence

$$\varphi(0, y, 0) \approx \frac{\pi a^2 \sigma}{y} \quad \text{for } y \gg a \quad (23)$$

Now $\pi a^2 \sigma$ is the total charge q on the disk, and Eq. 23 is just the expression for the potential due to a point charge of this magnitude. As we should expect, at a considerable distance from the disk (relative to its diameter), it doesn't matter much how the charge is shaped; only the total charge matters, in first approximation. In Fig. 2.9 we have drawn, as a dotted curve, the function $\pi a^2 \sigma / y$. You can see that the axial potential function approaches its asymptotic form pretty quickly.

It is not quite so easy to derive the potential for general points away from the axis of symmetry, because the definite integral isn't so simple. It proves to be something called an *elliptic integral*. These functions are well-known and tabulated, but there is no point in pursuing here mathematical details peculiar to a special problem. One further calculation, which is easy enough, may be instructive. We can find the potential at a point on the very edge of the disk, such as P_2 in Fig. 2.10.

To calculate the potential at P_2 we can consider first the thin wedge of length R and angular width $d\theta$ in Fig. 2.10. An element of the wedge, the black patch at distance r from P_2 , contains an amount of charge $\sigma r d\theta dr$. Its contribution to the potential at P_2 is therefore just $\sigma d\theta dr$. The contribution of the entire wedge is then $\sigma d\theta \int_0^R dr = \sigma R d\theta$. Now R is $2a \cos \theta$ from the geometry of the right triangle, and the whole disk is swept out as θ ranges from $-\pi/2$ to $\pi/2$. Thus we find the potential at P_2 :

$$\phi = \int_{-\pi/2}^{\pi/2} 2\sigma a \cos \theta d\theta = 4\sigma a \quad (24)$$

Comparing this with $2\pi\sigma a$, the potential at the center of the disk, we see that, as we should expect, the potential falls off from the center to the edge of the disk. The electric field, therefore, must have an *outward* component in the plane of the disk. That is why we remarked earlier that the charge, if free to move, would redistribute itself toward the rim. To put it another way, our uniformly charged disk is *not* a surface of constant potential, which any conducting surface must be unless charge is moving.†

The electric field on the symmetry axis can be computed directly from the potential function:

$$E_y = -\frac{\partial \varphi}{\partial y} = -\frac{d}{dy} 2\pi\sigma(\sqrt{y^2 + a^2} - y) \quad (25)$$

FIGURE 2.10

Finding the potential at a point P_2 on the rim of a uniformly charged disk.

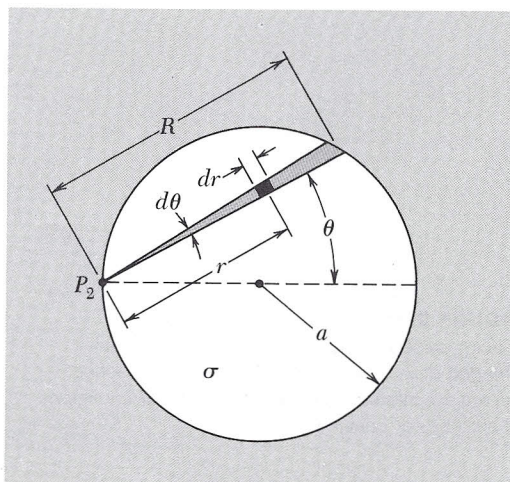

†The fact that conducting surfaces have to be equipotentials will be discussed thoroughly in Chapter 3.

giving

$$E_y = 2\pi\sigma \left[1 - \frac{y}{\sqrt{y^2 + a^2}} \right] \quad y > 0 \quad (26)$$

(To be sure, it is not hard to compute E_y directly from the charge distribution, for points on the axis.)

As y approaches zero from the positive side, E_y approaches $2\pi\sigma$. On the negative y side of the disk, which we shall call the back, \mathbf{E} points in the other direction and its y component E_y is $-2\pi\sigma$. This is the same as the field of an infinite sheet of charge of density σ , derived in Section 1.13. It ought to be, for at points close to the center of the disk, the presence or absence of charge out beyond the rim can't make much difference. In other words, any sheet looks infinite if viewed from close up. Indeed, E_y has the value $2\pi\sigma$ not only at the center but all over the disk.

In Fig. 2.11 we show some field lines for this system and also, plotted as dashed curves, the intersections on the yz plane of the surfaces of constant potential. Near the center of the disk these are lens-like surfaces, while at distances much greater than a they approach the spherical form of equipotential surfaces around a point charge.

Figure 2.11 illustrates a general property of field lines and equipotential surfaces. A field line through any point and the equipotential surface through that point *are perpendicular to one another*, just as, on a contour map of hilly terrain, the slope is steepest at right angles to a contour of constant elevation. This must be so, because if the field at any point had a component parallel to the equipotential surface through that point, it would require work to move a test charge along a constant-potential surface.

The energy associated with this electric field could be expressed as the integral over all space of $E^2 dv/8\pi$. It is equal to the work done in assembling this distribution, starting with infinitesimal charges far apart. In this particular example, as Problem 2.27 will demonstrate, that work is not hard to calculate directly if we know the potential at the rim of a uniformly charged disk.

There is a general relation between the work U required to assemble a charge distribution $\rho(x, y, z)$ and the potential $\phi(x, y, z)$ of that distribution:

$$U = \frac{1}{2} \int \rho\phi \, dv \quad (27)$$

Equation 9 of Chapter 1, for the energy of a system of discrete point charges, could have been written in this way:

$$U = \frac{1}{2} \sum_{j=1}^N q_j \sum_{k \neq j} \frac{q_k}{r_{jk}} \quad (28)$$

FIGURE 2.11

(Facing page.) The electric field of the uniformly charged disk. Solid curves are field lines. Dashed curves are intersections, with the plane of the figure, of surfaces of constant potential.

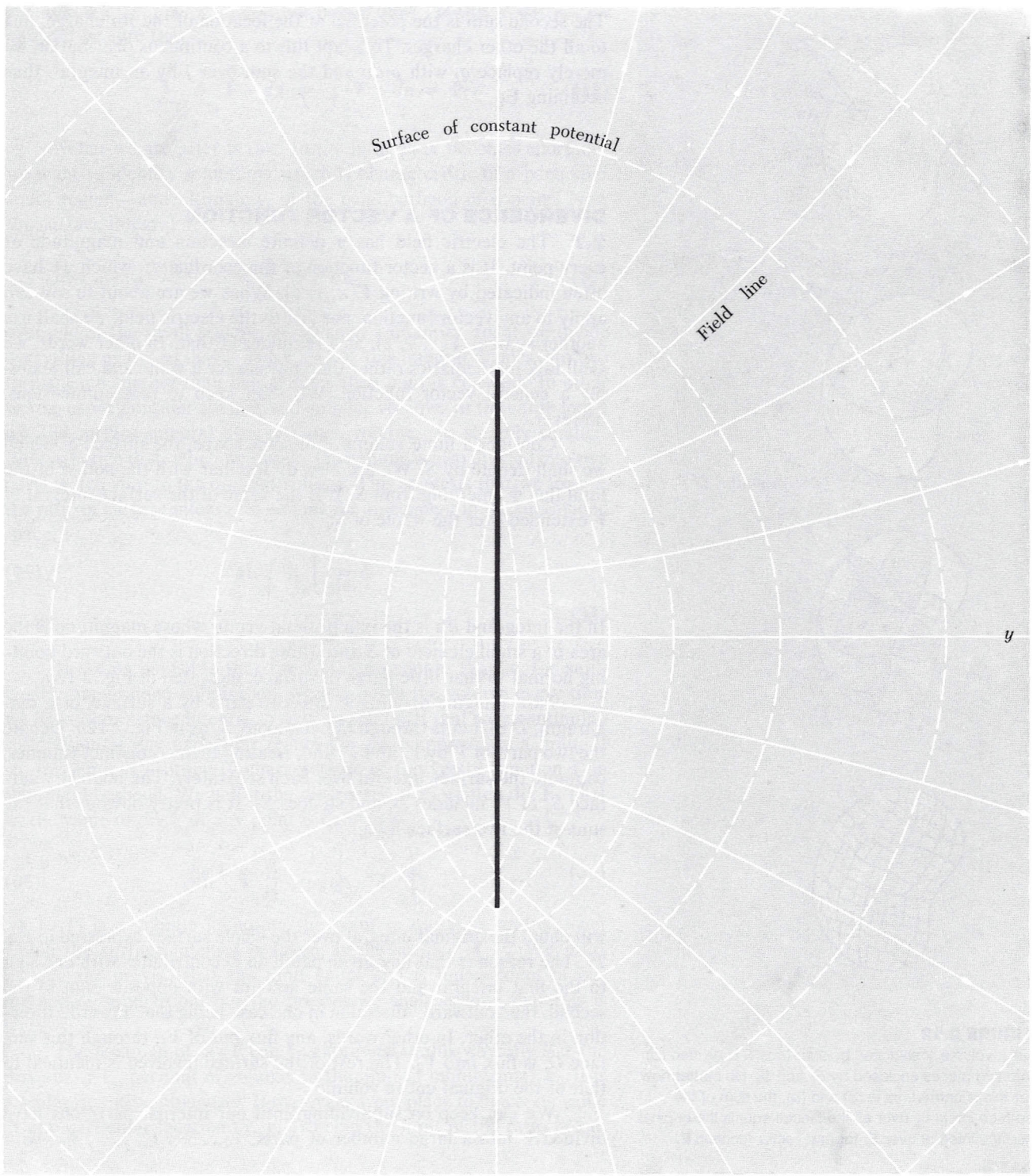

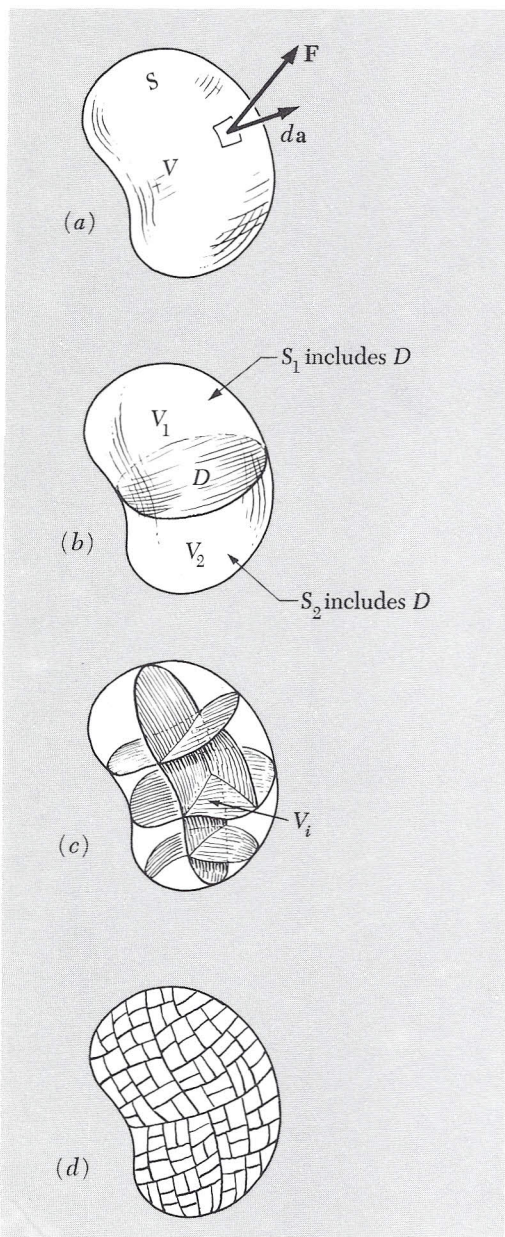
**FIGURE 2.12**

(a) A volume V enclosed by a surface S is divided (b) into two pieces enclosed by S_1 and S_2 . No matter how far this is carried, as in (c) and (d), the sum of the surface integrals over all the pieces equals the original surface integral over S , for any vector function \mathbf{F} .

The second sum is the potential at the location of the j th charge, due to all the other charges. To adapt this to a continuous distribution we merely replace q_j with ρdv and the sum over j by an integral, thus obtaining Eq. 27.

DIVERGENCE OF A VECTOR FUNCTION

2.7 The electric field has a definite direction and magnitude at every point. It is a vector function of the coordinates, which we have often indicated by writing $\mathbf{E}(x, y, z)$. What we are about to say can apply to any vector function, not just to the electric field; we shall use another symbol, $\mathbf{F}(x, y, z)$, as a reminder of that. In other words, we shall talk mathematics rather than physics for a while and call \mathbf{F} simply a general vector function. We shall keep to three dimensions, however.

Consider a finite volume V of some shape, the surface of which we shall denote by S . We are already familiar with the notion of the total flux Φ emerging from S . It is the value of the surface integral of \mathbf{F} extended over the whole of S :

$$\Phi = \int_S \mathbf{F} \cdot d\mathbf{a} \quad (29)$$

In the integrand $d\mathbf{a}$ is the infinitesimal vector whose magnitude is the area of a small element of S and whose direction is the outward-pointing normal to that little patch of surface, indicated in Fig. 2.12a.

Now imagine dividing V into two parts by a surface, or a diaphragm, D that cuts through the “balloon” S , as in Fig. 2.12b. Denote the two parts of V by V_1 and V_2 and, treating them as distinct volumes, compute the surface integral over each separately. The boundary surface S_1 of V_1 includes D , and so does S_2 . It is pretty obvious that the sum of the two surface integrals

$$\int_{S_1} \mathbf{F} \cdot d\mathbf{a}_1 + \int_{S_2} \mathbf{F} \cdot d\mathbf{a}_2 \quad (30)$$

will equal the original integral over the whole surface expressed in Eq. 29. The reason is that any given patch on D contributes with one sign to the first integral and the same amount with opposite sign to the second, the “outward” direction in one case being the “inward” direction in the other. In other words, any flux *out* of V_1 , through this surface D , is flux *into* V_2 . The rest of the surface involved is identical to that of the original entire volume.

We can keep on subdividing until our internal partitions have divided V into a large number of parts, $V_1, \dots, V_i, \dots, V_N$, with

surfaces $S_1, \dots, S_i, \dots, S_N$. No matter how far this is carried we can still be sure that

$$\sum_{i=1}^N \int_{S_i} \mathbf{F} \cdot d\mathbf{a}_i = \int_S \mathbf{F} \cdot d\mathbf{a} = \Phi \quad (31)$$

What we are after is this: In the limit as N becomes enormous we want to identify something which is characteristic of a particular small region—and ultimately, of the neighborhood of a point. Now the surface integral

$$\int_{S_i} \mathbf{F} \cdot d\mathbf{a}_i \quad (32)$$

over one of the small regions, is *not* such a quantity, for if we divide everything again, so that N becomes $2N$, this integral divides into two terms, each smaller than before since their sum is constant. In other words, as we consider smaller and smaller volumes in the same locality, the surface integral over one such volume gets steadily smaller. But we notice that, when we divide, the volume is also divided into two parts which sum to the original volume. This suggests that we look at the ratio of surface integral to volume for an element in the subdivided space:

$$\frac{\int_{S_i} \mathbf{F} \cdot d\mathbf{a}_i}{V_i} \quad (33)$$

It seems plausible that for N large enough, that is, for sufficiently fine-grained subdivision, we can halve the volume every time we halve the surface integral so that we shall find that with continuing subdivision of any particular region this ratio approaches a limit. If so, this limit is a property characteristic of the vector function \mathbf{F} in that neighborhood. We call it the *divergence* of \mathbf{F} , written $\text{div } \mathbf{F}$. That is, the value of $\text{div } \mathbf{F}$ at any point is defined as

$$\text{div } \mathbf{F} \equiv \lim_{V_i \rightarrow 0} \frac{1}{V_i} \int_{S_i} \mathbf{F} \cdot d\mathbf{a}_i \quad (34)$$

where V_i is a volume including the point in question, and S_i , over which the surface integral is taken, is the surface of V_i . We must include the proviso that the limit exists and is independent of our method of subdivision. For the present we shall assume that this is true.

The meaning of $\text{div } \mathbf{F}$ can be expressed in this way: $\text{div } \mathbf{F}$ is the flux out of V_i , per unit of volume, in the limit of infinitesimal V_i . It is a scalar quantity, obviously. It may vary from place to place, its value at any particular location (x, y, z) being the limit of the ratio in Eq.

34 as V_i is chopped smaller and smaller while always enclosing the point (x, y, z) . So $\text{div } \mathbf{F}$ is simply a scalar function of the coordinates.

GAUSS'S THEOREM AND THE DIFFERENTIAL FORM OF GAUSS'S LAW

2.8 If we know this scalar function of position $\text{div } \mathbf{F}$, we can work our way right back to the surface integral over a large volume: We first write Eq. 31 in this way:

$$\int_S \mathbf{F} \cdot d\mathbf{a} = \sum_{i=1}^N \int_{S_i} \mathbf{F} \cdot d\mathbf{a}_i = \sum_{i=1}^N V_i \left[\frac{\int_{S_i} \mathbf{F} \cdot d\mathbf{a}_i}{V_i} \right] \quad (35)$$

In the limit $N \rightarrow \infty$, $V_i \rightarrow 0$, the term in brackets becomes the divergence of \mathbf{F} and the sum goes into a volume integral:

$$\int_S \mathbf{F} \cdot d\mathbf{a} = \int_V \text{div } \mathbf{F} \, dv \quad (36)$$

Equation 36 is called Gauss's theorem, or the divergence theorem. It holds for any vector field for which the limit involved in Eq. 34 exists.

Let us see what this implies for the electric field \mathbf{E} . We have Gauss's law which assures us that

$$\int_S \mathbf{E} \cdot d\mathbf{a} = 4\pi \int_V \rho \, dv \quad (37)$$

If the divergence theorem holds for any vector field, it certainly holds for \mathbf{E} :

$$\int_S \mathbf{E} \cdot d\mathbf{a} = \int_V \text{div } \mathbf{E} \, dv \quad (38)$$

Both Eq. 37 and Eq. 38 hold for *any* volume we care to choose—of any shape, size, or location. Comparing them, we see that this can only be true if at every point,

$$\text{div } \mathbf{E} = 4\pi\rho \quad (39)$$

If we adopt the divergence theorem as part of our regular mathematical equipment from now on, we can regard Eq. 39 simply as an alter-

native statement of Gauss's law. It is Gauss's law in differential form, that is, stated in terms of a local relation between charge density and electric field.

THE DIVERGENCE IN CARTESIAN COORDINATES

2.9 While Eq. 34 is the fundamental definition of *divergence*, independent of any system of coordinates, it is useful to know how to calculate the divergence of a vector function when we are given its explicit form. Suppose a vector function \mathbf{F} is expressed as a function of cartesian coordinates x , y , and z . That means that we have three scalar functions, $F_x(x, y, z)$, $F_y(x, y, z)$, and $F_z(x, y, z)$. We'll take the region V_i in the shape of a little rectangular box, with one corner at the point (x, y, z) and sides Δx , Δy , and Δz , as in Fig. 2.13a. Whether some other shape will yield the same limit is a question we must face later.

Consider two opposite faces of the box, the top and bottom for instance, which would be represented by the vectors $\hat{\mathbf{z}} \Delta x \Delta y$ and $-\hat{\mathbf{z}} \Delta x \Delta y$. The flux through these faces involves only the z component of \mathbf{F} , and the net contribution depends on the *difference* between F_z at the top and F_z at the bottom or, more precisely, on the difference between the average of F_z over the top face and the average of F_z over the bottom face of the box. To the first order in small quantities this difference is $(\partial F_z / \partial z) \Delta z$. Figure 2.13b will help to explain this. The average value of F_z on the bottom surface of the box, if we consider only first-order variations in F_z over this small rectangle, is its value at the center of the rectangle. That value is, to first order[†] in Δx and Δy ,

$$F_z(x, y, z) + \frac{\Delta x}{2} \frac{\partial F_z}{\partial x} + \frac{\Delta y}{2} \frac{\partial F_z}{\partial y} \quad (40)$$

For the average of F_z over the top face we take the value at the center of the top face, which to first order in the small displacements is

$$F_z(x, y, z) + \frac{\Delta x}{2} \frac{\partial F_z}{\partial x} + \frac{\Delta y}{2} \frac{\partial F_z}{\partial y} + \Delta z \frac{\partial F_z}{\partial z} \quad (41)$$

[†]This is nothing but the beginning of a Taylor expansion of the scalar function F_z , in the neighborhood of (x, y, z) . That is, $F_z(x + a, y + b, z + c) = F_z(x, y, z) + \left(a \frac{\partial}{\partial x} + b \frac{\partial}{\partial y} + c \frac{\partial}{\partial z} \right) F_z + \dots + \left(\frac{1}{n!} \right) \left(a \frac{\partial}{\partial x} + b \frac{\partial}{\partial y} + c \frac{\partial}{\partial z} \right)^n F_z + \dots$. The derivatives are all to be evaluated at (x, y, z) . In our case $a = \Delta x/2$, $b = \Delta y/2$, $c = 0$, and we drop the higher-order terms in the expansion.

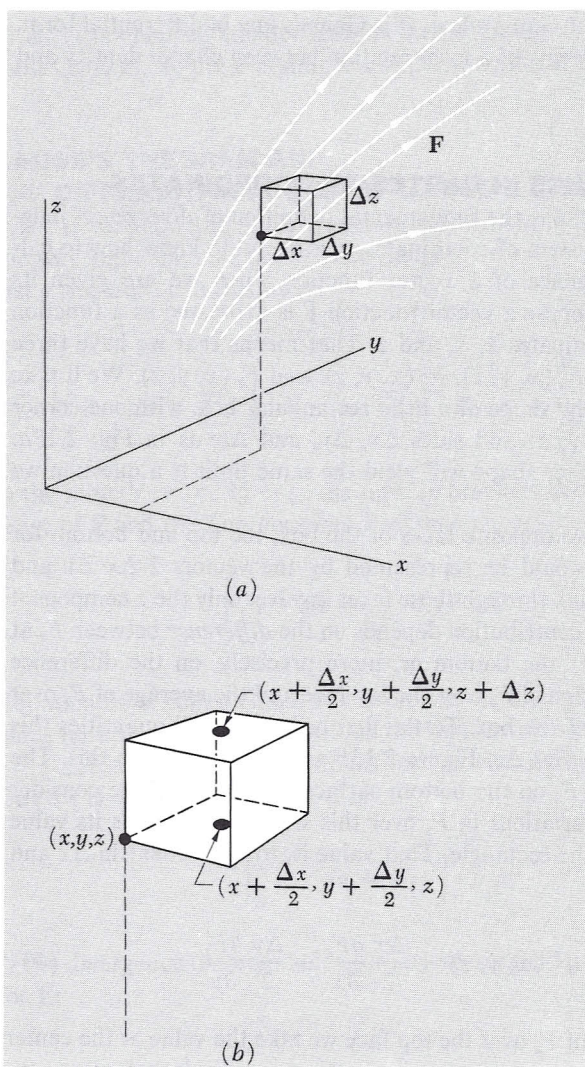
**FIGURE 2.13**

Calculation of flux from the box of volume $\Delta x \Delta y \Delta z$.

The net flux out of the box through these two faces, each of which has the area of $\Delta x \Delta y$, is therefore

$$\begin{aligned}
 & \underbrace{\Delta x \Delta y \left[F_z(x, y, z) + \frac{\Delta x}{2} \frac{\partial F_z}{\partial x} + \frac{\Delta y}{2} \frac{\partial F_z}{\partial y} + \Delta z \frac{\partial F_z}{\partial z} \right]}_{\text{(flux out of box at top)}} \\
 & - \underbrace{\Delta x \Delta y \left[F_z(x, y, z) + \frac{\Delta x}{2} \frac{\partial F_z}{\partial x} + \frac{\Delta y}{2} \frac{\partial F_z}{\partial y} \right]}_{\text{(flux into box at bottom)}} \quad (42)
 \end{aligned}$$

FIGURE 2.14

The limit of the flux/volume ratio is independent of the shape of the box.

which reduces to $\Delta x \Delta y \Delta z (\partial F_z / \partial z)$. Obviously, similar statements must apply to the other pairs of sides. That is, the net flux out of the box through the sides parallel to the yz plane is $\Delta y \Delta z \Delta x (\partial F_x / \partial x)$. Notice that the product $\Delta x \Delta y \Delta z$ occurs here too. Thus the total flux out of the little box is

$$\Phi = \Delta x \Delta y \Delta z \left(\frac{\partial F_x}{\partial x} + \frac{\partial F_y}{\partial y} + \frac{\partial F_z}{\partial z} \right) \quad (43)$$

The volume of the box is $\Delta x \Delta y \Delta z$, so the ratio of flux to volume is $\partial F_x / \partial x + \partial F_y / \partial y + \partial F_z / \partial z$, and as this expression does not contain the dimensions of the box at all, it remains as the limit when we let the box shrink. [Had we retained terms proportional to $(\Delta x)^2$, $(\Delta x \Delta y)$, etc., in the calculation of the flux, they would of course vanish on going to the limit.]

Now we can begin to see why this limit is going to be independent of the shape of the box. Obviously it is independent of the proportions of the rectangular box, but that isn't saying much. It is easy to see that it will be the same for any volume that we can make by sticking together little rectangular boxes of any size and shape. Consider the two boxes in Fig. 2.14. The sum of the flux Φ_1 out of box 1 and Φ_2 out of box 2 is not changed by removing the adjoining walls to make one box, for whatever flux went through that plane was negative flux for one and positive for the other. So we could have a bizarre shape like Fig. 2.14c without affecting the result. We leave it to the reader to generalize further. Tilted surfaces can be taken care of if you will first prove that the vector sum of the four surface areas of the tetrahedron in Fig. 2.15 is zero.

We conclude that, assuming only that the functions F_x , F_y , and F_z are differentiable, the limit does exist and is given by

$$\operatorname{div} \mathbf{F} = \frac{\partial F_x}{\partial x} + \frac{\partial F_y}{\partial y} + \frac{\partial F_z}{\partial z} \quad (44)$$

If $\operatorname{div} \mathbf{F}$ has a positive value at some point, we find—thinking of \mathbf{F} as a velocity field—a net “outflow” in that neighborhood. For instance, if all three partial derivatives in Eq. 44 are positive at a point P , we might have a vector field in that neighborhood something like that suggested in Fig. 2.16. But the field could look quite different and still have positive divergence, for any vector function \mathbf{G} such that $\operatorname{div} \mathbf{G} = 0$ could be superimposed. Thus one or two of the three partial derivatives could be negative, and we might still have $\operatorname{div} \mathbf{F} > 0$. The divergence is a quantity that expresses only one aspect of the spatial variation of a vector field.

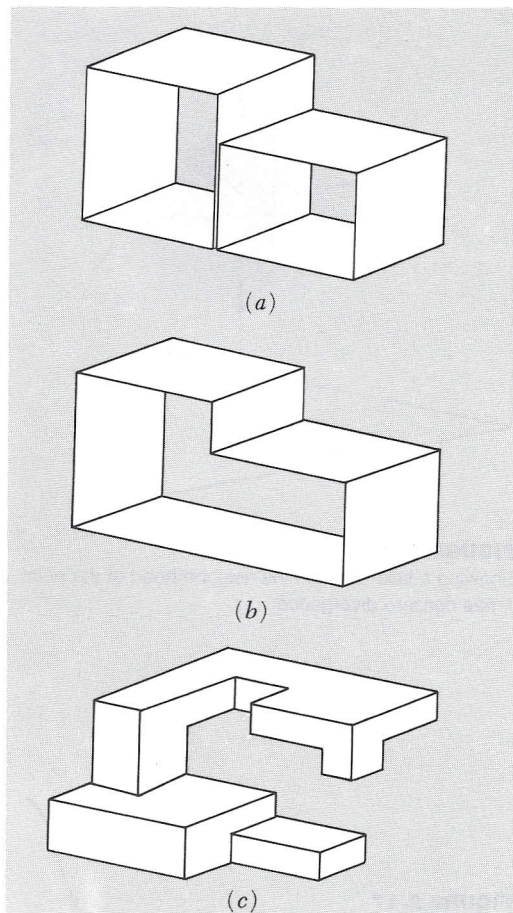
**FIGURE 2.15**

You can prove that $\mathbf{a}_1 + \mathbf{a}_2 + \mathbf{a}_3 + \mathbf{a}_4 = 0$.

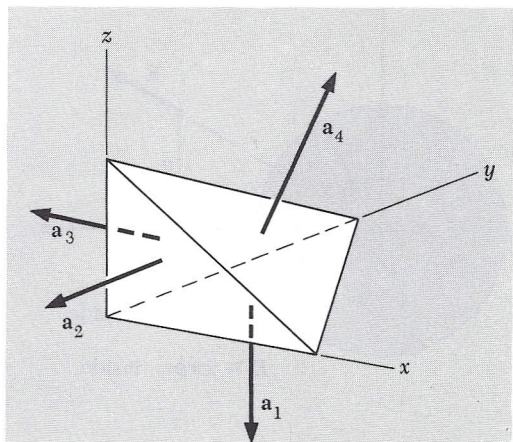

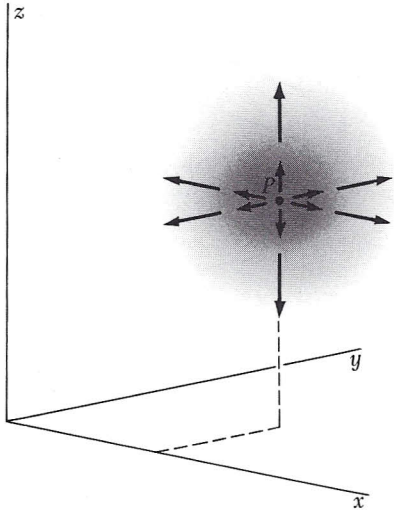
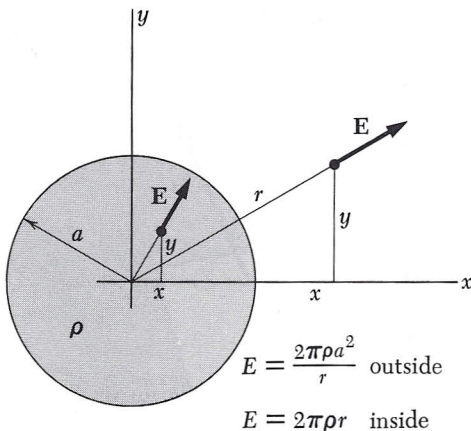

FIGURE 2.16

Showing a field which in the neighborhood of the point P has nonzero divergence.

FIGURE 2.17

The field inside and outside a uniform cylindrical distribution of charge.



Let's apply this to an electric field that is rather easy to visualize. An infinitely long circular cylinder of radius a is filled with a distribution of positive charge of density ρ . Outside the cylinder the electric field is the same as that of a line charge on the axis. It is a radial field with magnitude proportional to $1/r$. The field inside is found by applying Gauss' law to a cylinder of radius $r < a$. You can do this as an easy problem. You will find that the field inside is directly proportional to r , and of course it is radial also. The exact values are:

$$\begin{aligned} E &= \frac{2\pi\rho a^2}{r} & \text{for } r > a \\ E &= 2\pi\rho r & \text{for } r < a \end{aligned} \quad (45)$$

Figure 2.17 is a section perpendicular to the axis of the cylinder. Rectangular coordinates aren't the most natural choice here, but we'll use them anyway to get some practice with Eq. 44. With $r = \sqrt{x^2 + y^2}$, the field components are expressed as follows:

$$\begin{aligned} E_x &= \left(\frac{x}{r}\right) E = \frac{2\pi\rho a^2 x}{x^2 + y^2} & \text{for } r > a \\ &= 2\pi\rho x & \text{for } r < a \\ E_y &= \left(\frac{y}{r}\right) E = \frac{2\pi\rho a^2 y}{x^2 + y^2} & \text{for } r > a \\ &= 2\pi\rho y & \text{for } r < a \end{aligned} \quad (46)$$

E_z is zero, of course.

Outside the cylinder of charge, $\text{div } \mathbf{E}$ has the value given by

$$\begin{aligned} \frac{\partial E_x}{\partial x} + \frac{\partial E_y}{\partial y} &= 2\pi\rho a^2 \left[\frac{1}{x^2 + y^2} - \frac{2x^2}{(x^2 + y^2)^2} \right. \\ &\quad \left. + \frac{1}{x^2 + y^2} - \frac{2y^2}{(x^2 + y^2)^2} \right] = 0 \end{aligned} \quad (47)$$

Inside the cylinder, $\text{div } \mathbf{E}$ is

$$\frac{\partial E_x}{\partial x} + \frac{\partial E_y}{\partial y} = 2\pi\rho(1 + 1) = 4\pi\rho \quad (48)$$

We expected both results. Outside the cylinder where there is no charge, the net flux emerging from any volume—large or small—is zero, so the limit of the ratio *flux/volume* is certainly zero. Inside the cylinder we get the result required by the fundamental relation Eq. 39.

THE LAPLACIAN

2.10 We have now met two scalar functions related to the electric field, the potential function φ and the divergence, $\text{div } \mathbf{E}$. In cartesian coordinates the relationships are expressed as

$$\mathbf{E} = -\text{grad } \varphi = -\left(\hat{\mathbf{x}} \frac{\partial \varphi}{\partial x} + \hat{\mathbf{y}} \frac{\partial \varphi}{\partial y} + \hat{\mathbf{z}} \frac{\partial \varphi}{\partial z}\right) \quad (49)$$

$$\text{div } \mathbf{E} = \frac{\partial E_x}{\partial x} + \frac{\partial E_y}{\partial y} + \frac{\partial E_z}{\partial z} \quad (50)$$

Equation 49 shows that the x component of \mathbf{E} is $E_x = -\partial\varphi/\partial x$. Substituting this and the corresponding expressions for E_y and E_z into Eq. 50, we get a relation between $\text{div } \mathbf{E}$ and φ :

$$\text{div } \mathbf{E} = -\text{div grad } \varphi = -\left(\frac{\partial^2 \varphi}{\partial x^2} + \frac{\partial^2 \varphi}{\partial y^2} + \frac{\partial^2 \varphi}{\partial z^2}\right) \quad (51)$$

The operation on φ which is indicated by Eq. 51 except for the minus sign we could call “div grad,” or “taking the divergence of the gradient of. . .” The symbol used to represent this operation is ∇^2 , called *the Laplacian operator*, or just *the Laplacian*. The expression

$$\frac{\partial^2}{\partial x^2} + \frac{\partial^2}{\partial y^2} + \frac{\partial^2}{\partial z^2}$$

is the prescription for the Laplacian in cartesian coordinates.

The notation ∇^2 is explained as follows. The gradient operator is often symbolized by ∇ , called “del.” Writing it out in cartesian coordinates,

$$\nabla = \hat{\mathbf{x}} \frac{\partial}{\partial x} + \hat{\mathbf{y}} \frac{\partial}{\partial y} + \hat{\mathbf{z}} \frac{\partial}{\partial z} \quad (52)$$

If we handle this as a vector, then its square would be

$$\nabla \cdot \nabla = \frac{\partial^2}{\partial x^2} + \frac{\partial^2}{\partial y^2} + \frac{\partial^2}{\partial z^2} \quad (53)$$

the same as the Laplacian in cartesian coordinates. So the Laplacian is often called “del squared,” and we say “del squared φ ,” meaning “div grad φ .” *Warning:* In other coordinate systems, spherical polar coordinates, for instance, the explicit forms of the gradient operator and the Laplacian operator are not so simply related. It is well to remember that the fundamental definition of the Laplacian operation is “divergence of the gradient of.”

We can now express directly a *local* relation between the charge density at some point and the potential function in that immediate

neighborhood. From Gauss' law in differential form, $\text{div } \mathbf{E} = 4\pi\rho$, we have

$$\nabla^2\varphi = -4\pi\rho \quad (54)$$

Equation 54, sometimes called *Poisson's equation*, relates the charge density to the second derivatives of the potential. Written out in cartesian coordinates it is

$$\frac{\partial^2\varphi}{\partial x^2} + \frac{\partial^2\varphi}{\partial y^2} + \frac{\partial^2\varphi}{\partial z^2} = -4\pi\rho \quad (55)$$

One may regard this as the differential expression of the relationship expressed by an integral in Eq. 15, which tells us how to find the potential at a point by summing the contributions of all sources near and far.†

LAPLACE'S EQUATION

2.11 Wherever $\rho = 0$, that is, in all parts of space containing no electric charge, the electric potential φ has to satisfy the equation

$$\nabla^2\varphi = 0 \quad (56)$$

This is called *Laplace's equation*. We run into it in many branches of physics. Indeed one might say that from a mathematical point of view the theory of classical fields is mostly a study of the solutions of this equation. The class of functions that satisfy Laplace's equation are called *harmonic functions*. They have some remarkable properties, one of which is this: *If $\varphi(x, y, z)$ satisfies Laplace's equation, then the average value of φ over the surface of any sphere (not necessarily a small sphere) is equal to the value of φ at the center of the sphere.* We can easily prove that this must be true of the electric potential ϕ in regions containing no charge. Consider a point charge q and a spherical surface S over which a charge q' is uniformly distributed. Let the charge q be brought in from infinity to a distance R from the center of the charged sphere, as in Fig. 2.18. The electric field of the sphere being the same as if its total charge q' were concentrated at its center,

†In fact, it can be shown that Eq. 55 is the *mathematical* equivalent of Eq. 15. This means, if you apply the Laplacian operator to the integral in Eq. 15, you will come out with $-4\pi\rho$. We shall not stop to show how this is done; you'll have to take our word for it or figure out how to do it.

the work required is qq'/R . Now suppose, instead, that the point charge q was there first and the charged sphere was later brought in from infinity. The work required for that is the product of q' and the average over the surface S of the potential due to the point charge q . Now the work is surely the same in the second case, namely, qq'/R , so the average over the sphere of the potential due to q must be q/R . That is indeed the potential at the center of the sphere due to the external point charge q . That proves the assertion for any single point charge outside the sphere. But the potential of many charges is just the sum of the potentials due to the individual charges, and the average of a sum is the sum of the averages. It follows that the assertion must be true for *any* system of sources lying wholly outside the sphere S .

This property of the potential, that its average over an empty sphere is equal to its value at the center, is closely related to a fact that you may find disappointing: You can't construct an electrostatic field that will hold a charged particle in *stable* equilibrium in empty space. This particular "impossibility theorem," like others in physics, is useful in saving fruitless speculation and effort. Let us see why it is true. Suppose we have an electric field in which, contrary to the theorem, there *is* a point P at which a positively charged particle would be in stable equilibrium. That means that *any* small displacement of the particle from P must bring it to a place where an electric field acts to push it back toward P . But that means that a little sphere around P must have \mathbf{E} pointing inward *everywhere* on its surface. That contradicts Gauss's law, for there is no negative source charge within the region. (Our charged test particle doesn't count; besides, it's positive.) In other words, you can't have an empty region where the electric field points all inward or all outward, and that's what you would need for *stable* equilibrium. To express the same fact in terms of the electric potential, a stable position for a charged particle must be one where the potential φ is either lower than that at all neighboring points (if the particle is positively charged) or higher than that at all neighboring points (if the particle is negatively charged). Clearly neither is possible for a function whose average value over a sphere is always equal to its value at the center.

Of course one can have a charged particle in *equilibrium* in an electrostatic field, in the sense that the force on it is zero. The point where $\mathbf{E} = 0$ in Fig. 1.10 is such a location. The position midway between two equal positive charges is an equilibrium position for a third charge, either positive or negative. But the equilibrium is not stable. (Think what happens when the third charge is slightly displaced from its equilibrium position.) It *is* possible, by the way, to trap and hold stably an electrically charged particle by electric fields that vary in *time*.

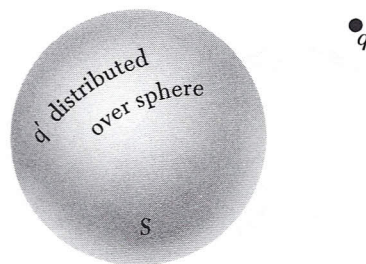

FIGURE 2.18

The work required to bring in q' and distribute it over the sphere is q' times the *average*, over the sphere, of the potential ϕ due to q .

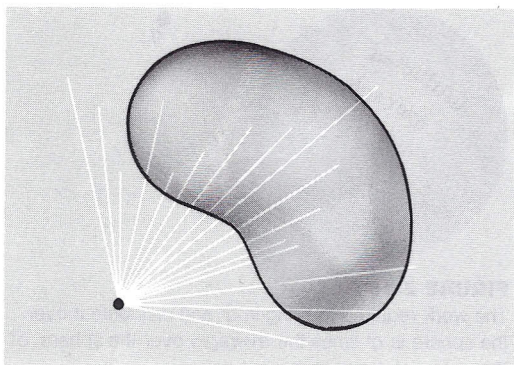

FIGURE 2.19

In a non-inverse-square field, the flux through a closed surface is not zero.

DISTINGUISHING THE PHYSICS FROM THE MATHEMATICS

2.12 In the last few sections we have been concerned with mathematical relations and new ways of expressing familiar facts. It may help to sort out physics from mathematics, and law from definition, if we try to imagine how things would be if the electric force were *not* a pure inverse-square force but instead a force with a finite range, for instance, a force varying like

$$\frac{e^{-\lambda r}}{r^2} \quad (57)$$

Then Gauss's law in the integral form expressed in Eq. 37 would surely fail, for by taking a very large surface enclosing some sources, we would find a vanishingly small field on this surface. The flux would go to zero as the surface expanded, rather than remain constant. However, we could still define a field at every point in space. We could calculate the divergence of that field, and Eq. 38, which describes a mathematical property of *any* vector field, would still be true. Is there a contradiction here? No, because Eq. 39 would also fail. The divergence of the field would no longer be the same as the source density. We can understand this by noting that a small volume empty of sources could still have a net flux through it owing to the effect of a source *outside* the volume, if the field has finite range. As suggested in Fig. 2.19, more flux would enter the side near the source than would leave the volume.

Thus we may say that Eqs. 37 and 39 express the same *physical law*, the inverse-square law that Coulomb established by direct measurement of the forces between charged bodies, while Eq. 38 is an expression of a *mathematical theorem* which enables us to translate our statement of this law from differential to integral form or the reverse. The relations that connect \mathbf{E} , ρ , and ϕ are gathered together in Fig. 2.20 and 2.20'.

How can we justify these differential relations between source and field in a world where electric charge is really not a smooth jelly but is concentrated on particles whose interior we know very little about? Actually, a statement like Eq. 54, Poisson's equation, is meaningful on a macroscopic scale only. The charge density ρ is to be interpreted as an average over some small but finite region containing many particles. Thus the function ρ cannot be continuous in the way a mathematician might prefer. When we let our region V_i shrink down in the course of demonstrating the differential form of Gauss's law, we know as physicists that we musn't let it shrink too far. That is awkward perhaps, but the fact is that we make out very well with the continuum model in large-scale electrical systems. In the atomic world we have the elementary particles, and vacuum. Inside the particles,

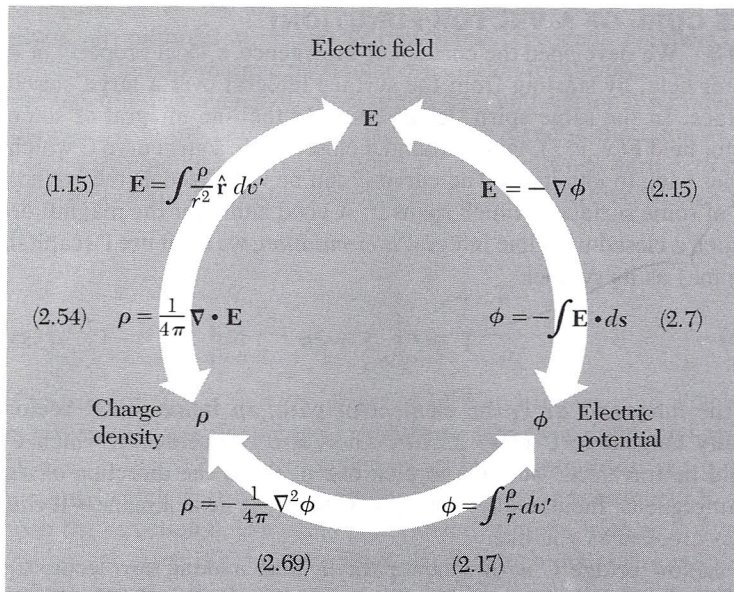

FIGURE 2.20

How electric charge density, electric potential, and electric field are related. The integral relations involve the line integral and the volume integral. The differential relations involve the gradient, the divergence, and div · grad or ∇^2 , the Laplacian operator. Charge density ρ is in esu/cm³, potential ϕ is in statvolts, field \mathbf{E} is in statvolt/cm, and all lengths in cm.

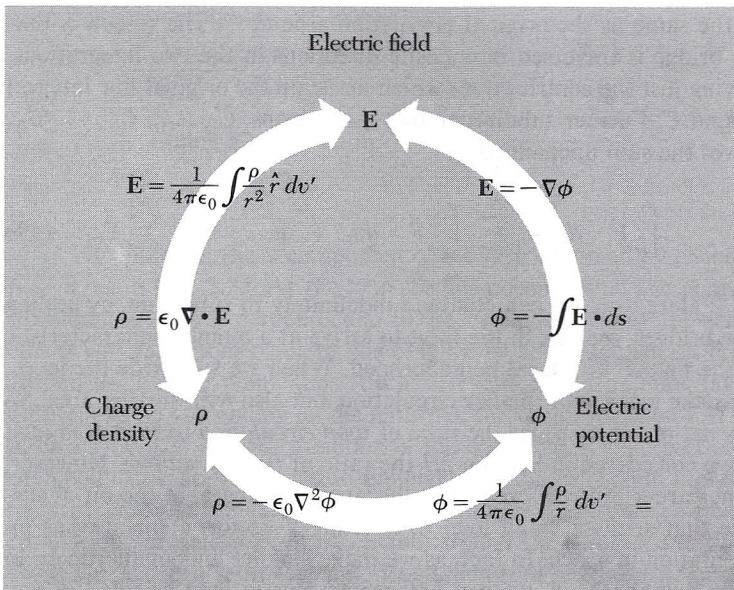

FIGURE 2.20'

The same relations in SI units. Charge density ρ is in coulomb/m³, potential ϕ is in volts, field \mathbf{E} is in volt/meter, and all lengths are in meters. ($\epsilon_0 = 8.854 \times 10^{-12}$ coulomb/volt-meter.)

even if Coulomb's law turns out to have some kind of meaning, much else is going on. The vacuum, so far as electrostatics is concerned, is ruled by Laplace's equation. Still, we cannot be sure that, even in the vacuum, passage to a limit of zero size has *physical* meaning.

THE CURL OF A VECTOR FUNCTION†

2.13 We developed the concept of divergence, a local property of a vector field, by starting from the surface integral over a large closed surface. In the same spirit, let us consider the line integral of some vector field $\mathbf{F}(x, y, z)$, taken around a closed path, some curve C which comes back to join itself. The curve C can be visualized as the boundary of some surface S which spans it. A good name for the magnitude of such a closed-path line integral is *circulation*; we shall use Γ (capital gamma) as its symbol:

$$\Gamma = \int_C \mathbf{F} \cdot ds \quad (58)$$

In the integrand ds is the element of path, an infinitesimal vector locally tangent to C (Fig. 2.21a). There are two senses in which C could be traversed; we have to pick one to make the direction of ds unambiguous. Incidentally, the curve C need not lie in a plane—it can be as crooked as you like.

Now bridge C with a new path B , thus making two loops, C_1 and C_2 , each of which includes B as part of itself (Fig. 2.21b). Take the line integral around each of these, in the same directional sense. It is easy to see that the sum of the two circulations, Γ_1 and Γ_2 , will be the same as the original circulation around C : The reason is that the bridge is traversed in opposite directions in the two integrations, leaving just the contributions which made up the original line integral around C . Further subdivision into many loops, $C_1, \dots, C_i, \dots, C_N$, leaves the sum unchanged:

$$\int_C \mathbf{F} \cdot ds = \sum_{i=1}^N \int_{C_i} \mathbf{F} \cdot ds_i \quad \text{or} \quad \Gamma = \sum_{i=1}^N \Gamma_i \quad (59)$$

Here, too, we can continue indefinitely to subdivide, by adding new bridges, seeking in the limit to arrive at a quantity characteristic of the field \mathbf{F} in a local neighborhood. When we subdivide the loops, we make loops with smaller circulation, but also with smaller area. So it is natural to consider the ratio of *loop circulation* to *loop area*, just as we considered in Section 2.7 the ratio of *flux* to *volume*. However, things are a little different here, because the area \mathbf{a}_i of the bit of surface that spans a small loop C_i is really a vector; a surface has an orientation in space. In fact, as we make smaller and smaller loops in some neighborhood, we can arrange to have a loop oriented in any direction we choose. (Remember, we are not committed to any partic-

FIGURE 2.21

For the subdivided loop, the sum of all the circulations Γ_i around the sections is equal to the circulation Γ around the original curve C .

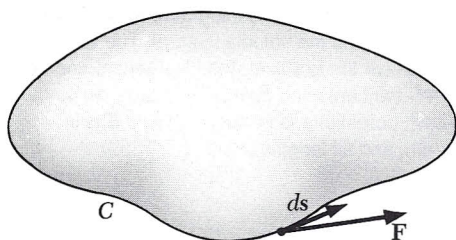

(a)

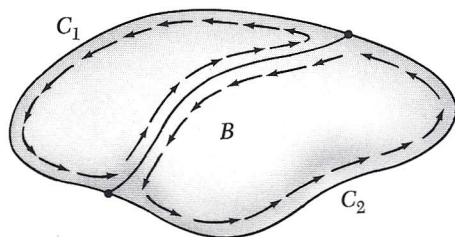

(b)

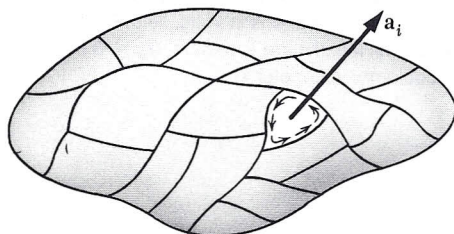

(c)

†Study of this section and the remainder of Chapter 2 can be postponed until Chapter 6 is reached. Until then our only application of this vector derivative will be the demonstration that an electrostatic field is characterized by $\text{curl } \mathbf{E} = 0$, as explained in Section 2.16.

ular surface over the whole curve C .) Thus we can pass to the limit in essentially different ways, and we must expect the result to reflect this.

Let us choose some particular orientation for the patch as it goes through the last stages of subdivision. The unit vector $\hat{\mathbf{n}}$ will denote the normal to the patch, which is to remain fixed in direction as the patch surrounding a particular point P shrinks down toward zero size. The limit of the *ratio of circulation to patch area* will be written this way:

$$\lim_{a_i \rightarrow 0} \frac{\Gamma_i}{a_i} \quad \text{or} \quad \lim_{a_i \rightarrow 0} \frac{\int_{C_i} \mathbf{F} \cdot d\mathbf{s}}{a_i} \quad (60)$$

The rule for sign is that the direction of $\hat{\mathbf{n}}$ and the sense in which C_i is traversed in the line integral shall be related by a right-hand-screw rule, as in Fig. 2.22. The limit we obtain by this procedure is a scalar quantity which is associated with the point P in the vector field \mathbf{F} , and with the direction $\hat{\mathbf{n}}$. We could pick three directions, such as $\hat{\mathbf{x}}$, $\hat{\mathbf{y}}$, and $\hat{\mathbf{z}}$, and get three different numbers. It turns out that these numbers can be considered components of a vector. We call the vector $\text{curl } \mathbf{F}$. That is to say, the number we get for the limit with $\hat{\mathbf{n}}$ in a particular direction is the component, in that direction, of the vector $\text{curl } \mathbf{F}$. To state this in an equation,

$$(\text{curl } \mathbf{F}) \cdot \hat{\mathbf{n}} = \lim_{a_i \rightarrow 0} \frac{\Gamma_i}{a_i} = \lim_{a_i \rightarrow 0} \frac{\int_{C_i} \mathbf{F} \cdot d\mathbf{s}}{a_i} \quad (61)$$

For instance, the x component of $\text{curl } \mathbf{F}$ is obtained by choosing $\hat{\mathbf{n}} = \hat{\mathbf{x}}$, as in Fig. 2.23. As the loop shrinks down around the point P , we keep it in a plane perpendicular to the x axis. In general, the vector $\text{curl } \mathbf{F}$ will vary from place to place. If we let the patch shrink down around some other point, the ratio of circulation to area may have a different value, depending on the nature of the vector function \mathbf{F} . That is, $\text{curl } \mathbf{F}$ is itself a vector function of the coordinates. Its direction at each point in space is normal to the plane through this point in which the circulation is a maximum. Its magnitude is the limiting value of circulation per unit area, in this plane, around the point in question.

The last two sentences might be taken as a definition of $\text{curl } \mathbf{F}$. Like Eq. 61 they make no reference to a coordinate frame. We have not proved that the object so named and defined is a vector; we have only asserted it. Possession of direction and magnitude is not enough to make something a vector. The components as defined must behave like vector components. Suppose we have determined certain values for the x , y , and z components of $\text{curl } \mathbf{F}$ by applying Eq. 61 with $\hat{\mathbf{n}}$

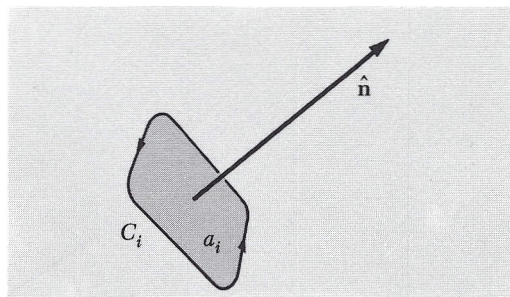
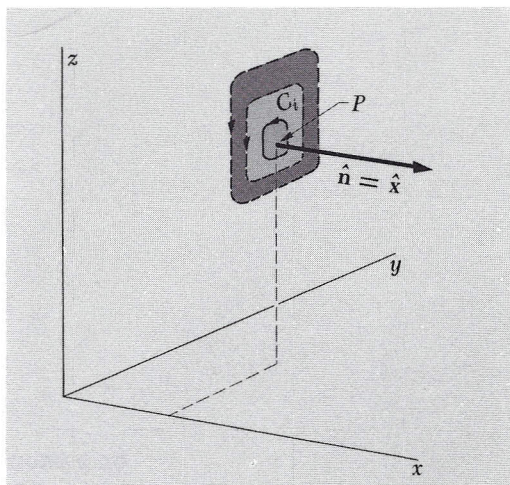

FIGURE 2.22

Right-hand-screw relation between the surface normal and the direction in which the circulation line integral is taken.

FIGURE 2.23

The patch shrinks around P , keeping its normal pointing in the x direction.



chosen, successively, as $\hat{\mathbf{x}}$, $\hat{\mathbf{y}}$, and $\hat{\mathbf{z}}$. If $\text{curl } \mathbf{F}$ is a vector, it is uniquely determined by these three components. If some fourth direction is now chosen for $\hat{\mathbf{n}}$, the left side of Eq. 61 is fixed and the quantity on the right, the circulation in the plane perpendicular to the new $\hat{\mathbf{n}}$, had better agree with it! Indeed, until one is sure that $\text{curl } \mathbf{F}$ is a vector, it is not even obvious that there can be at most one direction for which the circulation per unit area at P is maximum—as was tacitly assumed in the latter definition. In fact, Eq. 61 does define a vector, but we shall not give a proof of that.

STOKES' THEOREM

2.14 From the circulation around an infinitesimal patch of surface we can now work back to the circulation around the original large loop C :

$$\Gamma = \int_C \mathbf{F} \cdot d\mathbf{s} = \sum_{i=1}^N \Gamma_i = \sum_{i=1}^N a_i \left(\frac{\Gamma_i}{a_i} \right) \quad (62)$$

In the last step we merely multiplied and divided by a_i . Now observe what happens to the right-hand side as N is made enormous and all the a_i 's shrink. The quantity in parentheses becomes $(\text{curl } \mathbf{F}) \cdot \hat{\mathbf{n}}_i$, where $\hat{\mathbf{n}}_i$ is the unit vector normal to the i th patch. So we have on the right the sum, over all patches that make up the entire surface S spanning C , of the product "patch area times normal component of $(\text{curl } \mathbf{F})$." This is nothing but the *surface integral*, over S , of the vector $\text{curl } \mathbf{F}$:

$$\sum_{i=1}^N a_i \left(\frac{\Gamma_i}{a_i} \right) = \sum_{i=1}^N a_i (\text{curl } \mathbf{F}) \cdot \hat{\mathbf{n}}_i \rightarrow \int_S d\mathbf{a} \cdot \text{curl } \mathbf{F} \quad (63)$$

We thus find that

$$\int_C \mathbf{F} \cdot d\mathbf{s} = \int_S \text{curl } \mathbf{F} \cdot d\mathbf{a} \quad (64)$$

The relation expressed by Eq. 64 is a mathematical theorem called Stokes' theorem. Note how it resembles Gauss's theorem, the divergence theorem, in structure. Stokes' theorem relates the line integral of a vector to the surface integral of the curl of the vector. Gauss's theorem (Eq. 36) relates the surface integral of a vector to the volume integral of the divergence of the vector. Stokes' theorem involves a surface and the curve that bounds it. Gauss' theorem involves a volume and the surface that encloses it.

THE CURL IN CARTESIAN COORDINATES

2.15 Equation 61 is the fundamental definition of curl \mathbf{F} , stated without reference to any particular coordinate system. In this respect it is like our fundamental definition of divergence, Eq. 34. As in that case, we should like to know how to calculate curl \mathbf{F} when the vector function $\mathbf{F}(x, y, z)$ is explicitly given. To find the rule, we carry out the integration called for in Eq. 61, but we do it over a path of very simple shape, one that encloses a rectangular patch of surface parallel to the xy plane (Fig. 2.24). That is, we are taking $\hat{\mathbf{n}} = \hat{\mathbf{z}}$. In agreement with our rule about sign, the direction of integration around the rim

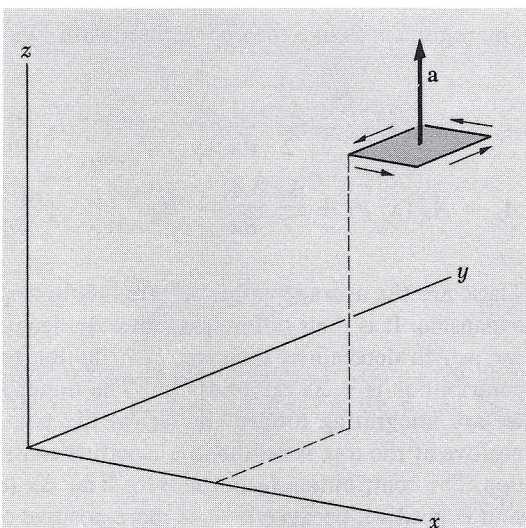

FIGURE 2.24

Circulation around a rectangular patch with $\hat{\mathbf{n}} = \hat{\mathbf{z}}$.

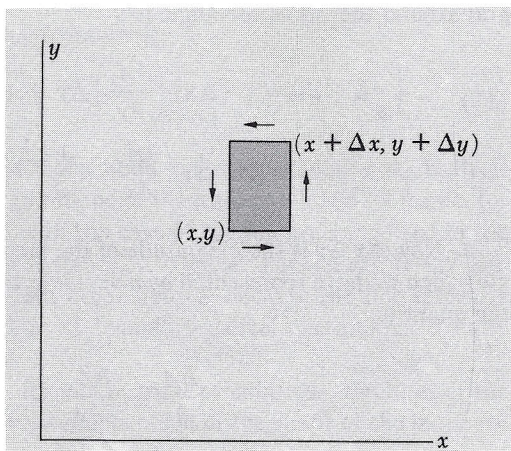

FIGURE 2.25

Looking down on the patch in Fig. 2.24.

must be clockwise as seen by someone looking up in the direction of \hat{n} . In Fig. 2.25 we look down onto the rectangle from above.

The line integral of \mathbf{A} around such a path depends on the variation of A_x with y and the variation of A_y with x . For if A_x had the same average value along the top of the frame, in Fig. 2.25, as along the bottom of the frame, the contribution of these two pieces of the whole line integral would obviously cancel. A similar remark applies to the side members. To the first order in the small quantities Δx and Δy , the difference between the average of A_x over the top segment of path at $y + \Delta y$ and its average over the bottom segment at y is

$$\left(\frac{\partial A_x}{\partial y}\right) \Delta y \quad (65)$$

The argument is like the one we used with Fig. 2.13*b*.

$$A_x = A_x(x, y) + \frac{\Delta x}{2} \frac{\partial A_x}{\partial x} \quad \left(\begin{array}{l} \text{at midpoint of} \\ \text{bottom of frame} \end{array}\right) \quad (66)$$

$$A_x = A_x(x, y) + \frac{\Delta x}{2} \frac{\partial A_x}{\partial x} + \Delta y \frac{\partial A_x}{\partial y} \quad \left(\begin{array}{l} \text{at midpoint of} \\ \text{top of frame} \end{array}\right)$$

These are the average values referred to, to first order in the Taylor's expansion. It is their difference, times the length of the path segment Δx , which determines their net contribution to the circulation. This contribution is $-\Delta x \Delta y (\partial A_x / \partial y)$. The minus sign comes in because we are integrating toward the left at the top, so that if A_x is more positive at the top, it results in a negative contribution to the circulation. The contribution from the sides is $\Delta y \Delta x (\partial A_y / \partial x)$, and here the sign is positive, because if A_y is more positive on the right, the result is a positive contribution to the circulation.

Thus, neglecting any higher powers of Δx and Δy , the line integral around the whole rectangle is

$$\begin{aligned} \int_{\square} \mathbf{A} \cdot d\mathbf{s} &= (-\Delta x) \left(\frac{\partial A_x}{\partial y}\right) \Delta y + (\Delta y) \left(\frac{\partial A_y}{\partial x}\right) \Delta x \quad (67) \\ &= \Delta x \Delta y \left(\frac{\partial A_y}{\partial x} - \frac{\partial A_x}{\partial y}\right) \end{aligned}$$

Now $\Delta x \Delta y$ is the magnitude of the area of the enclosed rectangle which we have represented by a vector in the z direction. Evidently the quantity

$$\frac{\partial A_y}{\partial x} - \frac{\partial A_x}{\partial y} \quad (68)$$

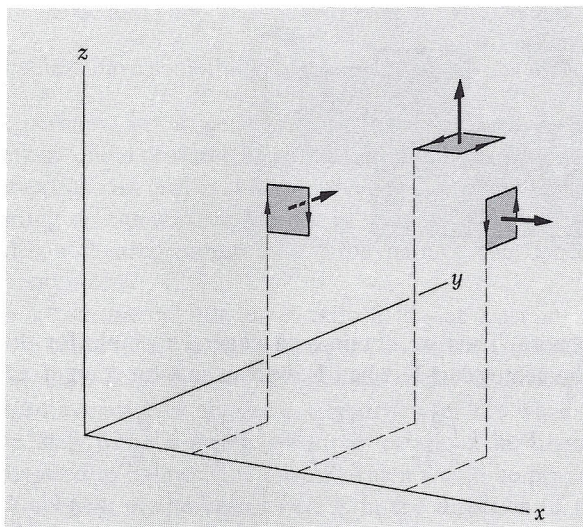
**FIGURE 2.26**

For each orientation, the limit of the ratio circulation/area determines a component of curl \mathbf{A} at that point. To determine all components of the vector curl \mathbf{A} at any point, the patches should all cluster around that point; here they are separated for clarity.

is the limit of the ratio

$$\frac{\text{Line integral around patch}}{\text{Area of patch}} \quad (69)$$

as the patch shrinks to zero size. If the rectangular frame had been oriented with its normal in the positive y direction, we would have found the expression

$$\frac{\partial A_x}{\partial z} - \frac{\partial A_z}{\partial x} \quad (70)$$

for the limit of the corresponding ratio, and if the frame had been oriented with its normal in the x direction, like the frame on the right in Fig. 2.26, we would have obtained

$$\frac{\partial A_z}{\partial y} - \frac{\partial A_y}{\partial z} \quad (71)$$

Although we have considered only rectangles, our result is actually independent of the shape of the little patch and its frame, for reasons much the same as in the case of the integrals involved in the divergence theorem. For instance, it is clear that we can freely join different rectangles to form other figures, because the line integrals along the merging sections of boundary cancel one another exactly (Fig. 2.27).

We conclude that, for any of these orientations, the limit of the ratio of circulation to area is independent of the shape of the patch we

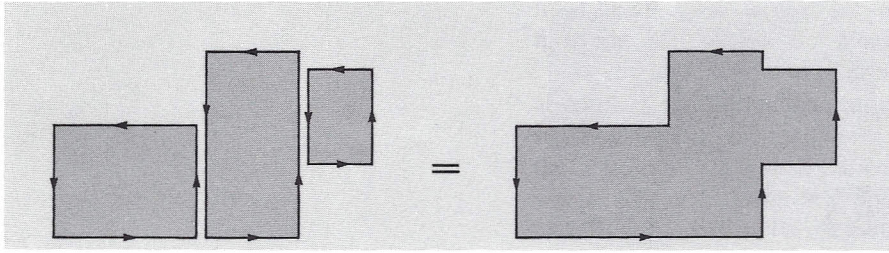
**FIGURE 2.27**

The circulation in the loop at the right is the sum of the circulations in the rectangles, and the area on the right is the sum of the rectangular areas. This diagram shows why the circulation/area ratio is independent of shape.

choose. Thus we obtain as a general formula for the components of the vector curl \mathbf{F} , when \mathbf{F} is given as a function of x , y , and z :

$$\text{curl } \mathbf{F} = \hat{\mathbf{x}} \left(\frac{\partial F_z}{\partial y} - \frac{\partial F_y}{\partial z} \right) + \hat{\mathbf{y}} \left(\frac{\partial F_x}{\partial z} - \frac{\partial F_z}{\partial x} \right) + \hat{\mathbf{z}} \left(\frac{\partial F_y}{\partial x} - \frac{\partial F_x}{\partial y} \right) \quad (72)$$

You may find the following rule easier to remember than the formula itself: Make up a determinant like this:

$$\begin{vmatrix} \hat{\mathbf{x}} & \hat{\mathbf{y}} & \hat{\mathbf{z}} \\ \frac{\partial}{\partial x} & \frac{\partial}{\partial y} & \frac{\partial}{\partial z} \\ F_x & F_y & F_z \end{vmatrix} \quad (73)$$

Expand it according to the rule for determinants, and you will get curl \mathbf{F} as given by Eq. 72. Notice that the x component of curl \mathbf{F} depends on the rate of change of F_z in the y direction and the negative of the rate of change of F_y in the z direction, and so on.

The symbol $\nabla \times$, read as “del cross,” where ∇ is interpreted as the “vector”

$$\hat{\mathbf{x}} \frac{\partial}{\partial x} + \hat{\mathbf{y}} \frac{\partial}{\partial y} + \hat{\mathbf{z}} \frac{\partial}{\partial z} \quad (74)$$

is often used in place of the name *curl*. If we write $\nabla \times \mathbf{F}$ and follow the rules for forming the components of a vector cross product, we get automatically the vector, curl \mathbf{F} . So curl \mathbf{F} and $\nabla \times \mathbf{F}$ mean the same thing.

THE PHYSICAL MEANING OF THE CURL

2.16 The name *curl* reminds us that a vector field with a nonzero curl has circulation, or vorticity. Maxwell used the name *rotation*, and in German a similar name is still used, abbreviated *rot*. Imagine a

velocity vector field \mathbf{G} , and suppose that $\text{curl } \mathbf{G}$ is not zero. Then the velocities in this field have something of this character: $\begin{array}{c} \leftarrow \\ \downarrow \uparrow \\ \rightarrow \\ \leftarrow \end{array}$ or $\begin{array}{c} \rightarrow \\ \uparrow \downarrow \\ \leftarrow \\ \rightarrow \end{array}$ superimposed, perhaps, on a general flow in one direction. For instance, the velocity field of water flowing out of a bathtub generally acquires a circulation. Its curl is not zero over most of the surface. Something floating on the surface rotates as it moves along. In the physics of fluid flow, hydrodynamics and aerodynamics, this concept is of central importance.

To make a “curlmeter” for an electric field—at least in our imagination—we could fasten positive charges to a hub by insulating spokes, as in Fig. 2.28. Exploring an electric field with this device, we would find, wherever $\text{curl } \mathbf{E}$ is not zero, a tendency for the wheel to turn around the shaft. With a spring to restrain rotation, the amount of twist could be used to indicate the torque, which would be proportional to the component of the vector $\text{curl } \mathbf{E}$ in the direction of the

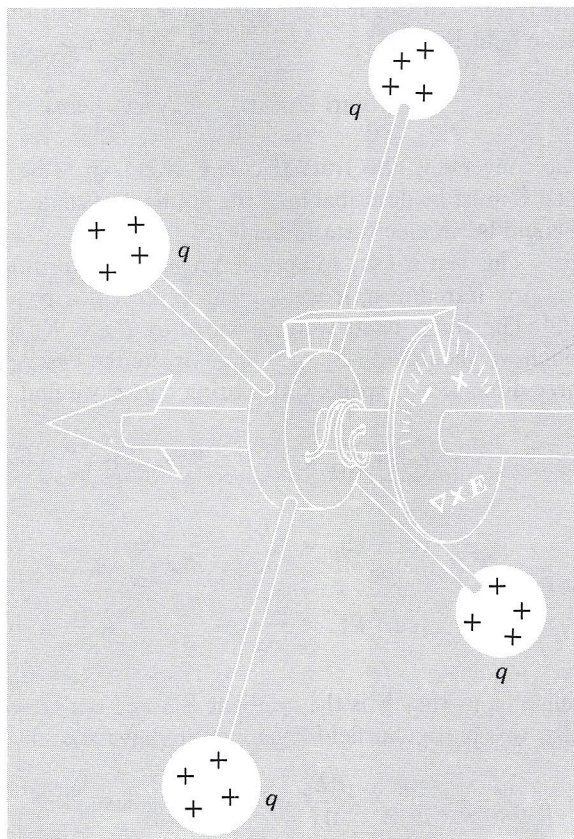

FIGURE 2.28

The curlmeter.

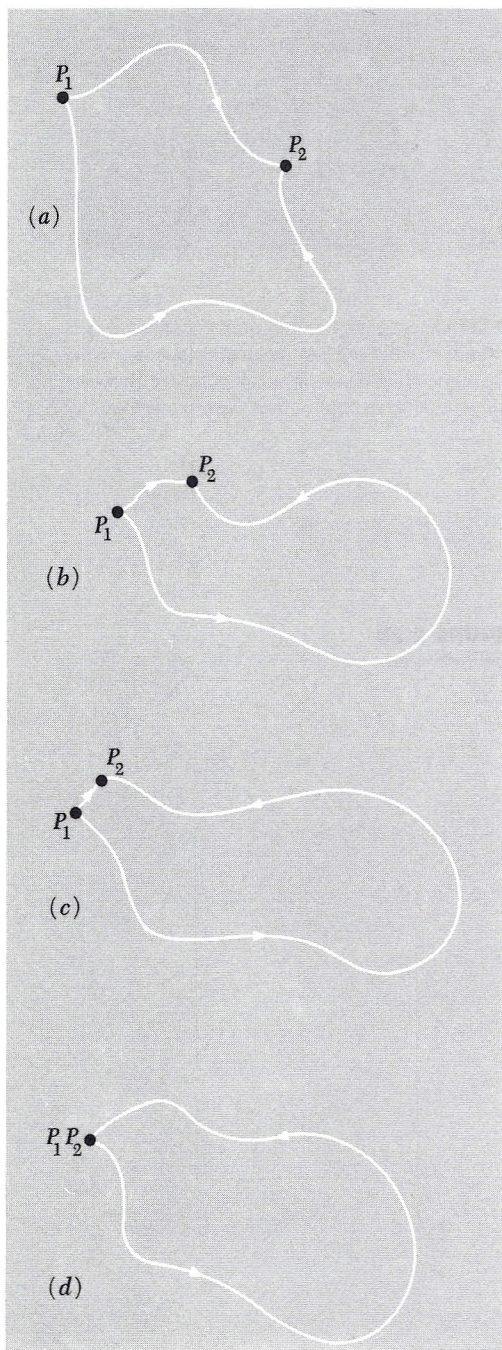

FIGURE 2.29

If the line integral between P_1 and P_2 is independent of path, the line integral around a closed loop must be zero.

shaft. If we can find the direction of the shaft for which the torque is maximum, and clockwise, that is the direction of the vector $\text{curl } \mathbf{E}$. (Of course, we cannot trust the curlmeter in a field which varies greatly within the dimensions of the wheel itself.)

What can we say, in the light of all this, about the *electrostatic* field \mathbf{E} ? The conclusion we can draw is a simple one: The curlmeter will always read zero! That follows from a fact we have already learned; namely, in the electrostatic field the line integral of \mathbf{E} around *any* closed path is zero. Just to recall why this is so, remember that the line integral of \mathbf{E} between any two points such as P_1 and P_2 in Fig. 2.29 is independent of the path. As we bring the two points P_1 and P_2 close together, the line integral over the shorter path in the figure obviously vanishes—unless the final location is at a singularity such as a point charge, a case we can rule out. So the line integral must be zero over the closed loop in Fig. 2.29d. But now, if the circulation is zero around *any* closed path, it follows from Stokes' theorem that the surface integral of $\text{curl } \mathbf{E}$ is zero over a patch of any size, shape, or location. But then $\text{curl } \mathbf{E}$ must be zero *everywhere*, for if it were not zero somewhere we could devise a patch in that neighborhood to violate the conclusion. All this leads to the simple statement that in the electrostatic field \mathbf{E} :

$$\text{curl } \mathbf{E} = 0 \quad (\text{everywhere}) \quad (75)$$

The converse is also true. If $\text{curl } \mathbf{E}$ is known to be zero everywhere, then \mathbf{E} must be describable as the gradient of some potential function; it could be an electrostatic field.

This test is easy to apply. When the vector function in Fig. 2.3 was first introduced, it was said to represent a possible electrostatic field. The components were specified by $E_x = Ky$ and $E_y = Kx$, to which we should add $E_z = 0$ to complete the description of a field in three-dimensional space. Calculating $\text{curl } \mathbf{E}$ we find

$$\begin{aligned} (\text{curl } \mathbf{E})_x &= \frac{\partial E_z}{\partial y} - \frac{\partial E_y}{\partial z} = 0 \\ (\text{curl } \mathbf{E})_y &= \frac{\partial E_x}{\partial z} - \frac{\partial E_z}{\partial x} = 0 \\ (\text{curl } \mathbf{E})_z &= \frac{\partial E_y}{\partial x} - \frac{\partial E_x}{\partial y} = K - K = 0 \end{aligned} \quad (76)$$

This tells us that \mathbf{E} is the gradient of some scalar potential. Incidentally, this particular field \mathbf{E} happens to have zero divergence also:

$$\frac{\partial E_x}{\partial x} + \frac{\partial E_y}{\partial y} + \frac{\partial E_z}{\partial z} = 0 \quad (77)$$

It therefore represents an electrostatic field in a *charge-free* region.

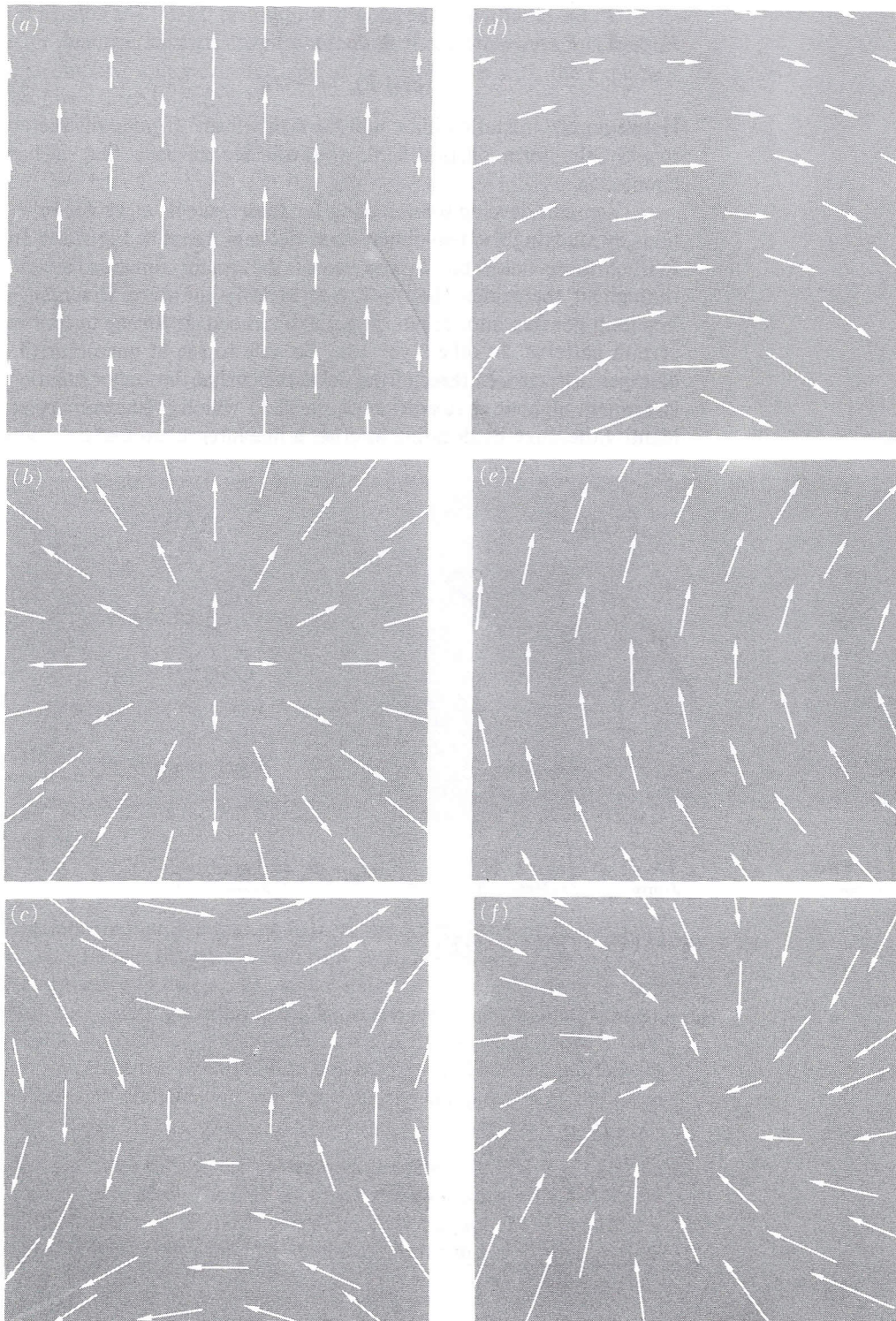
**FIGURE 2.30**

Four of these vector fields have zero divergence in the region shown. Three have zero curl. Can you spot them?

On the other hand, the equally simple vector function defined by $F_x = Ky$; $F_y = -Kx$; $F_z = 0$, does *not* have zero curl. Instead,

$$(\text{curl } \mathbf{F})_z = -2K \quad (78)$$

Hence no electrostatic field could have this form. If you will sketch roughly the form of this field, you will see at once that it has circulation.

You can develop some feeling for these aspects of vector functions by studying the two-dimensional fields pictured in Fig. 2.30. In four of these fields the divergence of the vector function is zero throughout the region shown. Try to identify the four. Divergence implies a net flux into, or out of, a neighborhood. It is easy to spot in certain patterns. In others you may be able to see at once that the divergence is zero. In three of the fields the curl of the vector function is zero throughout that portion of the field which is shown. Try to identify the three by deciding whether a line integral around any loop

FIGURE 2.31

Some vector relations summarized.

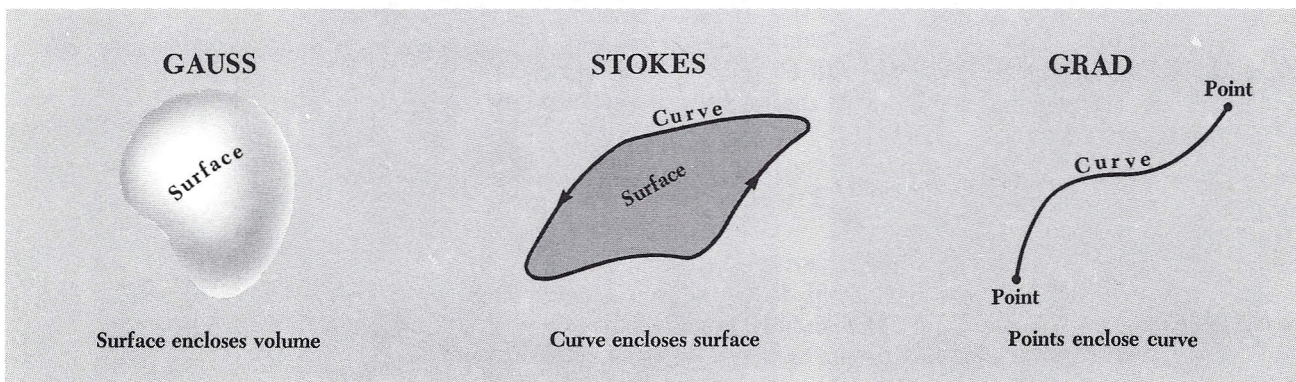

$$\int_{\text{surface}} \mathbf{F} \cdot d\mathbf{a} = \int_{\text{volume}} \text{div } \mathbf{F} \, dv$$

$$\int_{\text{curve}} \mathbf{A} \cdot d\mathbf{s} = \int_{\text{surface}} \text{curl } \mathbf{A} \cdot d\mathbf{a}$$

$$\varphi_2 - \varphi_1 = \int_{\text{curve}} \text{grad } \varphi \cdot d\mathbf{s}$$

IN CARTESIAN COORDINATES

$$\begin{aligned} \text{div } \mathbf{F} &= \frac{\partial F_x}{\partial x} + \frac{\partial F_y}{\partial y} + \frac{\partial F_z}{\partial z} \\ &= \nabla \cdot \mathbf{F} \end{aligned}$$

$$\begin{aligned} \text{curl } \mathbf{A} &= \hat{x} \left(\frac{\partial A_z}{\partial y} - \frac{\partial A_y}{\partial z} \right) \\ &\quad + \hat{y} \left(\frac{\partial A_x}{\partial z} - \frac{\partial A_z}{\partial x} \right) \\ &\quad + \hat{z} \left(\frac{\partial A_y}{\partial x} - \frac{\partial A_x}{\partial y} \right) \\ &= \nabla \times \mathbf{A} \end{aligned}$$

$$\begin{aligned} \text{grad } \varphi &= \hat{x} \frac{\partial \varphi}{\partial x} + \hat{y} \frac{\partial \varphi}{\partial y} + \hat{z} \frac{\partial \varphi}{\partial z} \\ &= \nabla \varphi \end{aligned}$$

$$\nabla = \hat{x} \frac{\partial}{\partial x} + \hat{y} \frac{\partial}{\partial y} + \hat{z} \frac{\partial}{\partial z}$$

would or would not be zero in each picture. That is the essence of *curl*. After you have studied the pictures, think about these questions before you compare your reasoning and your conclusions with the explanation given later in Fig. 2.32.

The curl of a vector field will prove to be a valuable tool later on when we deal with electric and magnetic fields whose curl is *not* zero. We have developed it at this point because the ideas involved are so close to those involved in the divergence. We may say that we have met two kinds of derivatives of a vector field. One kind, the divergence, involves the rate of change of a vector component in its own direction, $\partial F_x/\partial x$, and so on. The other kind, the curl, is a sort of “sideways derivative,” involving the rate of change of F_x as we move in the y or z direction.

The relations called Gauss’s theorem and Stokes’ theorem are summarized in Fig. 2.31. The connection between the scalar potential function and the line integral of its gradient can also be looked on as a member of this family of theorems and is included in the third column.

PROBLEMS

2.1 The vector function which follows represents a possible electrostatic field:

$$E_x = 6xy \quad E_y = 3x^2 - 3y^2 \quad E_z = 0$$

Calculate the line integral of \mathbf{E} from the point $(0, 0, 0)$ to the point $(x_1, y_1, 0)$ along the path which runs straight from $(0, 0, 0)$ to $(x_1, 0, 0)$ and thence to $(x_1, y_1, 0)$. Make a similar calculation for the path which runs along the other two sides of the rectangle, via the point $(0, y_1, 0)$. You ought to get the same answer if the assertion above is true. Now you have the potential function $\phi(x, y, z)$. Take the gradient of this function and see that you get back the components of the given field.

2.2 Consider the system of two charges shown in Fig. 2.7. Let z be the coordinate along the line on which the two charges lie, with $z = 0$ at the location of the positive charge. Make a plot of the potential ϕ along this line, plotting ϕ in statvolts against z in cm, from $z = -5$ to $z = 15$.

2.3 A charge of 2 esu is located at the origin. Two charges of -1 esu each are located at the point with x, y, z coordinates 1, 1, 0 and $-1, 1, 0$. It is easy to see that the potential ϕ is zero at the point (0, 1, 0) if it is zero at infinity. It follows that somewhere on the y axis beyond (0, 1, 0) the function $\phi(0, y, 0)$ must have a minimum or a maximum. At that point the electric field \mathbf{E} must be zero. Why? Locate the point, at least approximately.

Ans. $y = 1.6207$.

2.4 Describe the electric field and the charge distribution that go with the following potential:

$$\begin{aligned}\phi &= x^2 + y^2 + z^2 && \text{for } x^2 + y^2 + z^2 < a^2 \\ \phi &= -a^2 + \frac{2a^3}{(x^2 + y^2 + z^2)^{1/2}} && \text{for } a^2 < x^2 + y^2 + z^2\end{aligned}$$

2.5 A sphere the size of a basketball is charged to a potential of -1000 volts. About how many extra electrons are on it, per cm^2 of surface?

Ans. 3×10^7 .

2.6 A sphere the size of the earth has 1 coulomb of charge distributed evenly over its surface. What is the electric field strength just outside the surface, in volts/meter? What is the potential of the sphere, in volts, with zero potential at infinity?

Ans. 2.5×10^{-4} volt/meter; 1500 volts.

2.7 Designate the corners of a square, 5 cm on a side, in clockwise order, A, B, C, D . Put a charge 2 esu at A , -3 esu at B . Determine the value of the line integral of \mathbf{E} , from point C to point D . (No actual integration needed!)

2.8 For the cylinder of uniform charge density in Fig. 2.17:

(a) Show that the expression there given for the field inside the cylinder follows from Gauss's law.

(b) Find the potential ϕ as a function of r , both inside and outside the cylinder, taking $\phi = 0$ at $r = 0$.

2.9 For the system in Fig. 2.10 sketch the equipotential surface that touches the rim of the disk. Find the point where it intersects the symmetry axis.

2.10 A thin rod extends along the z axis from $z = -d$ to $z = d$. The rod carries a charge uniformly distributed along its length with linear charge density λ . By integrating over this charge distribution calculate the potential at a point P_1 on the z axis with coordinates 0, 0, $2d$. By another integration find the potential at a point P_2 on the x

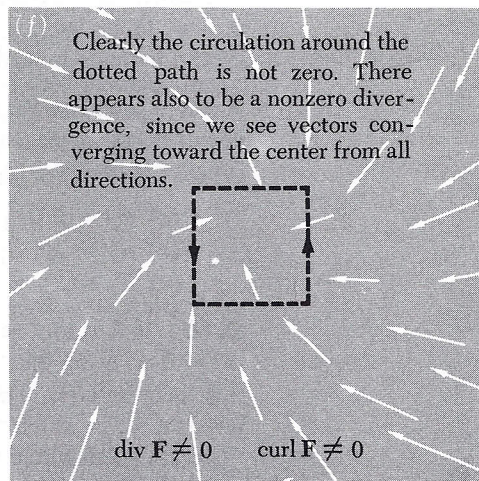
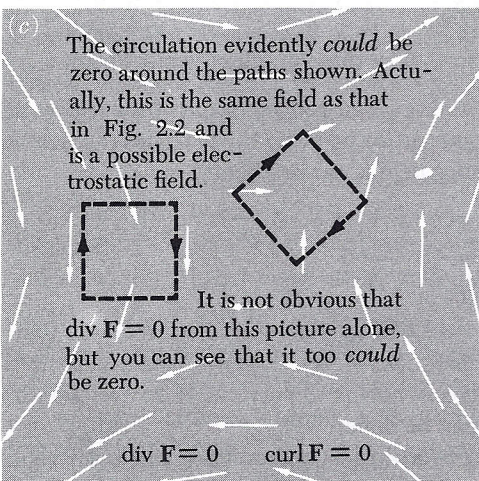
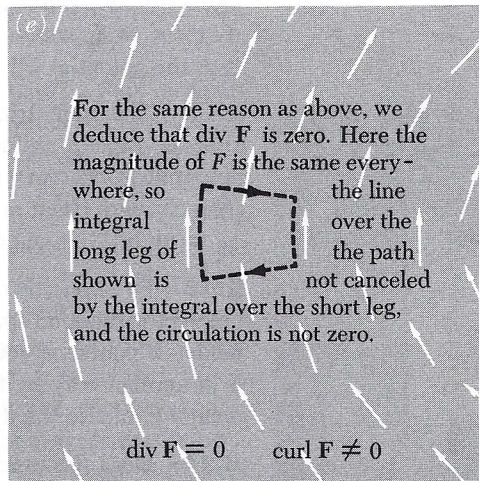
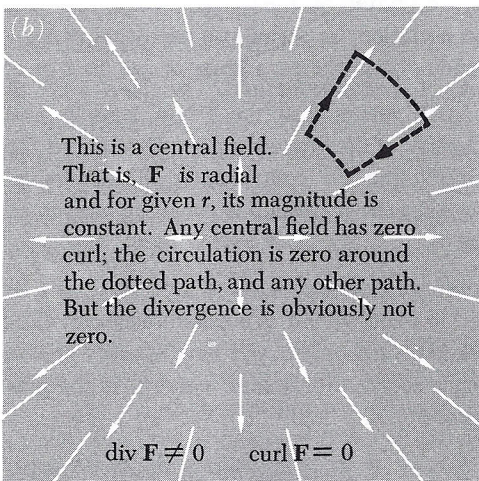
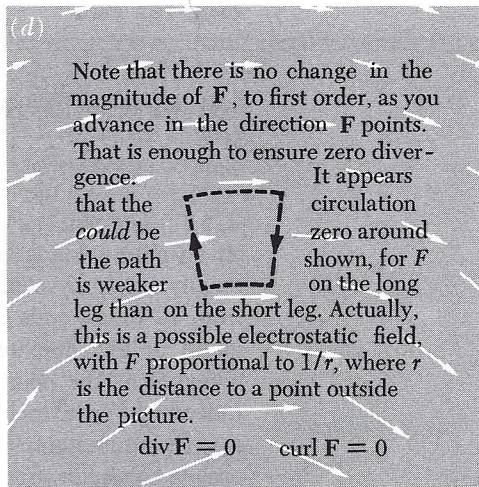
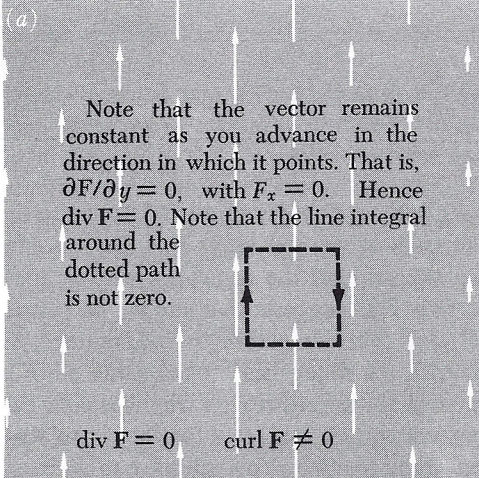

FIGURE 2.32
Discussion of Fig. 2.30.

axis and locate this point to make the potential equal to the potential at P_1 .

$$\text{Ans. } \lambda \ln 3; x = \sqrt{3}d.$$

2.11 The points P_1 and P_2 in the preceding problem happen to lie on an ellipse which has the ends of the rod as its foci, as you can readily verify by comparing the sums of the distances from P_1 and from P_2 to the ends of the rod. This suggests that the whole ellipse might be an equipotential. Test that conjecture by calculating the potential at the point $(3d/2, 0, d)$ which lies on the same ellipse. Indeed it is true, though there is no obvious reason why it should be, that the equipotential surfaces of this system are a family of confocal prolate spheroids. See if you can prove that. You will have to derive a formula for the potential at a general point $(x, 0, z)$ in the xz plane. Then show that, if x and z are related by the equation $x^2/(a^2 - d^2) + z^2/a^2 = 1$, which is the equation for an ellipse with foci at $z = \pm d$, the potential will depend only on the parameter a , not on x or z .

2.12 The right triangle with vertex P at the origin, base b , and altitude a has a uniform density of surface charge σ . Determine the potential at the vertex P . First find the contribution of the vertical strip of width dx at x . Show that the potential at P can be written as $\phi_P = \sigma b \ln[(1 + \sin \theta)/\cos \theta]$.

2.13 By explicitly calculating the components of $\nabla \times \mathbf{E}$, show that the vector function specified in Problem 2.1 is a possible electrostatic field. (Of course, if you worked that problem, you have already proved it in another way by finding a scalar function of which it is the gradient.) Evaluate the divergence of this field.

2.14 Does the function $f(x, y) = x^2 + y^2$ satisfy the two-dimensional Laplace's equation? Does the function $g(x, y) = x^2 - y^2$? Sketch the latter function, calculate the gradient at the points $(x = 0, y = 1)$; $(x = 1, y = 0)$; $(x = 0, y = -1)$; and $(x = -1, y = 0)$ and indicate by little arrows how these gradient vectors point.

2.15 Calculate the curl and the divergence of each of the following vector fields. If the curl turns out to be zero, try to discover a scalar function ϕ of which the vector field is the gradient:

$$(a) F_x = x + y; F_y = -x + y; F_z = -2z.$$

$$(b) G_x = 2y; G_y = 2x + 3z; G_z = 3y.$$

$$(c) H_x = x^2 - z^2; H_y = 2; H_z = 2xz.$$

2.16 If \mathbf{A} is any vector field with continuous derivatives, $\text{div}(\text{curl } \mathbf{A}) = 0$ or, using the "del" notation, $\nabla \cdot (\nabla \times \mathbf{A}) = 0$. We shall need this theorem later. The problem now is to prove it. Here are two different ways in which that can be done:

(a) (Uninspired straightforward calculation in a particular coor-

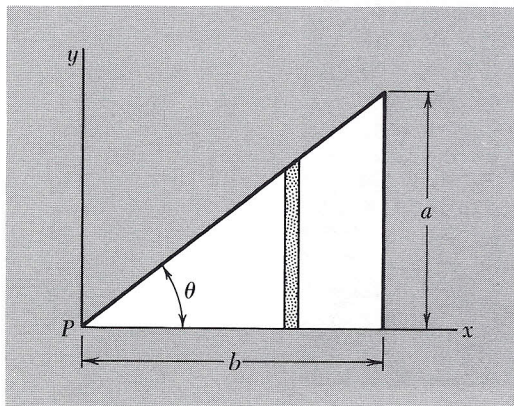

PROBLEM 2.12

ordinate system): Using the formula for ∇ in cartesian coordinates, work out the string of second partial derivatives that $\nabla \cdot (\nabla \times \mathbf{A})$ implies.

(b) (With the divergence theorem and Stokes' theorem, no coordinates are needed): Consider the surface S in the figure, a balloon almost cut in two which is bounded by the closed curve C . Think about the line integral, over a curve like C , of any vector field. Then invoke Stokes and Gauss with suitable arguments.

2.17 Use the identity $\nabla(\phi\nabla\phi) = (\nabla\phi)^2 + \phi\nabla^2\phi$ and the divergence theorem to prove that Eq. 38 of Chapter 1 and Eq. 27 of Chapter 2 are equivalent for any charge distribution of finite extent.

2.18 A hollow circular cylinder, of radius a and length b , with open ends, has a total charge Q uniformly distributed over its surface. What is the difference in potential between a point on the axis at one end and the midpoint of the axis? Show by sketching some field lines how you think the field of this thing ought to look.

2.19 We have two metal spheres, of radii R_1 and R_2 , quite far apart from one another compared with these radii. Given a total amount of charge Q which we have to divide between the spheres, how should it be divided so as to make the potential energy of the resulting charge distribution as small as possible? To answer this, first calculate the potential energy of the system for an arbitrary division of the charge, q on one and $Q - q$ on the other. Then minimize the energy as a function of q . You may assume that any charge put on one of these spheres distributes itself uniformly over the sphere, the other sphere being far enough away so that its influence can be neglected. When you have found the optimum division of the charge, show that with that division the potential difference between the two spheres is zero. (Hence they could be connected by a wire, and there would still be no redistribution. This is a special example of a very general principle we shall meet in Chapter 3: on a conductor, charge distributes itself so as to minimize the total potential energy of the system.)

2.20 As a distribution of electric charge, the gold nucleus can be described as a sphere of radius 6×10^{-13} cm with a charge $Q = 79e$ distributed fairly uniformly through its interior. What is the potential ϕ_0 at the center of the nucleus, expressed in megavolts? (First derive a general formula for ϕ_0 for a sphere of charge Q and radius a . Do this by using Gauss's law to find the internal and external electric field and then integrating to find the potential.)

Ans. $\phi = 3Q/2a = 95,000$ statvolts = 28.5 megavolts.

2.21 Suppose eight protons are permanently fixed at the corners of a cube. A ninth proton floats freely near the center of the cube. There are no other charges around, and no gravity. Is the ninth proton trapped? Can it find an escape route that is all down hill in potential

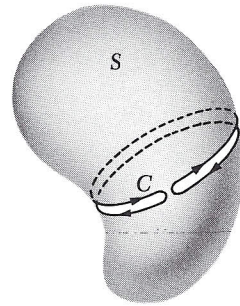

PROBLEM 2.16

energy? Test it with your calculator. Many-digit accuracy will be needed!

2.22 An interstellar dust grain, roughly spherical with a radius of 3×10^{-7} meters, has acquired a negative charge such that its potential is -0.15 volt. How many extra electrons has it picked up? What is the strength of the electric field at its surface, expressed in volts/meter?

2.23 By means of a van de Graaff generator, protons are accelerated through a potential difference of 5×10^6 volts. The proton beam then passes through a thin silver foil. The atomic number of silver is 47, and you may assume that a silver nucleus is so massive compared with the proton that its motion may be neglected. What is the closest possible distance of approach, of any proton, to a silver nucleus? What will be the strength of the electric field acting on the proton at that position?

2.24 Which of the two boxed statements in Section 2.1 we regard as the corollary of the other is arbitrary. Show that, if the line integral

$\int \mathbf{E} \cdot d\mathbf{s}$ is zero around any closed path, it follows that the line integral between two different points is path-independent.

2.25 Two point charges of strength 2 esu each, and two point charges of strength -1 esu each are symmetrically located in the xy plane as follows: The two positive charges are at $(0, 2)$ and $(0, -2)$, the two negative charges at $(1, 0)$ and $(-1, 0)$. Some of the equipotentials in the xy plane have been plotted in the figure. (Of course these curves are really the intersection of some three-dimensional equipotential surfaces with the xy plane.) Study this figure until you understand its general appearance. Now find the value of the potential ϕ on each of the curves A , B , and C , as usual taking $\phi = 0$ at infinite distance. Do this by calculating the potential at some point on the curve, a point chosen to make the calculation as easy as possible. Roughly sketch in some intermediate equipotentials.

2.26 Use the result for Problem 2.12 to answer this question: If a square with surface charge density σ and side s has the same potential at its center as a disk with the same surface charge density and diameter d , what must be the ratio s/d ? Is your answer reasonable?

2.27 Use the result stated in Eq. 24 to calculate the energy stored in the electric field of the charged disk described in Section 2.6. (*Hint*: Consider the work done in building the disk of charge out from zero radius to radius a by adding successive rings of width dr . Express the total energy in terms of radius a and total charge $Q = \pi a^2 \sigma$.)

Ans. $8Q^2/3\pi a$.

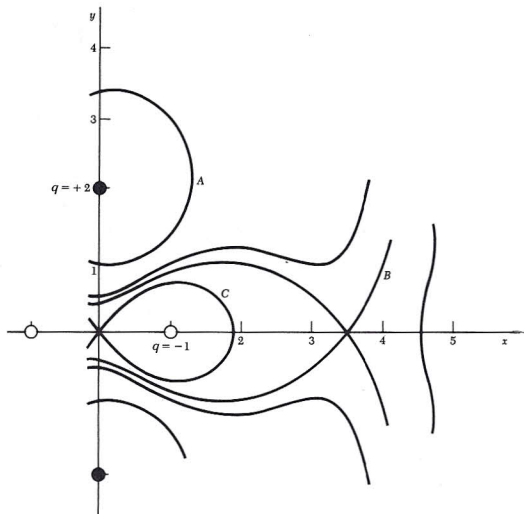

PROBLEM 2.25

2.28 A thin disk, radius 3 cm, has a circular hole of radius 1 cm in the middle. There is a uniform surface charge of -4 esu/cm^2 on the disk.

(a) What is the potential in statvolts at the center of the hole? (Assume zero potential at infinite distance.)

(b) An electron, starting from rest at the center of the hole, moves out along the axis, experiencing no forces except repulsion by the charges on the disk. What velocity does it ultimately attain? (Electron mass = $9 \times 10^{-28} \text{ gm.}$)

2.29 One of two nonconducting spherical shells of radius a carries a charge Q uniformly distributed over its surface, the other a charge $-Q$, also uniformly distributed. The spheres are brought together until they touch. What does the electric field look like, both outside and inside the shells? How much work is needed to move them far apart?

2.30 Consider a charge distribution which has the constant density ρ everywhere inside a cube of edge b and is zero everywhere outside that cube. Letting the electric potential ϕ be zero at infinite distance from the cube of charge, denote by ϕ_0 the potential at the center of the cube and ϕ_1 the potential at a corner of the cube. Determine the ratio ϕ_0/ϕ_1 . The answer can be found with very little calculation by combining a dimensional argument with superposition. (Think about the potential at the center of a cube with the same charge density and with twice the edge length.)

2.31 A flat nonconducting sheet lies in the xy plane. The only charges in the system are on this sheet. In the half-space above the sheet, $z > 0$, the potential is $\phi = \phi_0 e^{-kz} \cos kx$, where ϕ_0 and k are constants.

(a) Verify that ϕ satisfies Laplace's equation in the space above the sheet.

(b) What do the electric field lines look like?

(c) Describe the charge distribution on the sheet.

2.32 To show that it takes more than direction and magnitude to make a vector, let's try to define a vector which we'll name $\text{surl } \mathbf{F}$ by a relation like Eq. 61 with the right-hand side squared:

$$(\text{surl } \mathbf{F}) \cdot \hat{\mathbf{n}} = \left[\lim_{a_i \rightarrow 0} \frac{\int_{C_i} \mathbf{F} \cdot d\mathbf{s}}{a_i} \right]^2$$

Prove that this does *not* define a vector. (*Hint:* Consider reversing the direction of $\hat{\mathbf{n}}$.)